



Vrije Universiteit Brussel

FACULTEIT Ingenieurwetenschappen
VAKGROEP Werktuigkunde

Autonomous Mobile Robot Mechanical Design

Eindwerk ingediend tot het behalen van de academische graad
burgerlijk werktuigkundig-elektrotechnisch ingenieur

Kristof Goris

Academiejaar 2004-2005

Promotor: Prof. Dr. Ir. Dirk Lefeber
Co-Promotor: Prof. Dr. Ir. Hichem Sahli



Acknowledgements

Many people have helped me along the way. Their guidance, good humour, advice and inspiration sustained me through the months of work. First of all, I'd like to thank all of them.

Furthermore, I thank Mark and Guillermo for a nice cooperation during this project.

I wish to thank my promoters Prof. Dr. Ir. Dirk Lefeber and Prof. Dr. Ir. Hichem Sahli for proposing this challenging project. And for their confidence in my abilities.

Many thanks go out to my supervisors, the support of Ir. Ronald Van Ham, Ir. Bram Vanderborght, Ir. Thomas Geerinck, and Ir. Geert De Cubber kept me on the right track during the year.

Many thanks go out to Jean-Paul Schepens, André Plasschaert, Gabriël Van den Nest, Daniel Debondt, Eduard Schots and Thierry Lenoir for their technical support, great work, and patience with me.

Furthermore, I wish to thank the WERK department for placing its infrastructure and material at my disposal.

Finally I'd like to thank family and friends for being so supportive. I wouldn't have managed without them.

Executive Summaries

Autonomous Mobile Robot: Mechanical Design

The design of autonomous mobile robots capable of intelligent motion and action without requiring either a guide to follow or a teleoperator control involves the integration of many different bodies of knowledge. This makes mobile robotics a challenge worthwhile. To solve locomotion problems the mobile roboticist must understand mechanisms and kinematics, dynamics and control theory. To create robust perceptual systems, the mobile roboticist must leverage the fields of signal analysis and specialized bodies of knowledge such as computer visions to properly employ a multitude of sensor technologies. Localization and navigation demand knowledge of computer algorithms, information theory, artificial intelligence, and probability theory.

This thesis aims at building a locomotion mechanism that forms the base of a complete mobile robot system capable of finding its way autonomously through a path filled with obstacles. To accomplish this task, locomotion mechanisms and their kinematics have to be studied, mechanisms have to be designed and developed. The implementation of high and low level operating systems and electronics is required as well to control the chassis' motion.

Autonome Mobiele Robot: Mechanisch Ontwerp

Het ontwerp van een autonome mobiele robot die in staat moet zijn intelligente bewegingen en acties uit te voeren zonder hulp van een operator of gids, vereist de integratie van verschillende technologieën. Dit maakt mobiele robotica interdisciplinair en vervolgens een boeiende uitdaging. Om problemen op te lossen omtrent beweging moet men kennis nemen van mechanica, kinematica, dynamica en controle theorie. Robuuste gewaarwording systemen vereisen de kennis van signaal analyse en computer beeldverwerking, evenals sensor technologieën. Plaatsbepaling en navigatie vereisen computer algoritmes, informatie theorie, artificiële intelligentie en waarschijnlijkheid theorie.

Het doel van deze thesis bestaat erin een bewegings mechanisme uit te werken dat de basis vormt voor een complete mobiele robot die in staat is om zelfstandig zijn weg te vinden doorheen een met obstakels gevulde ruimte. Hiertoe worden verscheidene mogelijke bewegings mechanismen en hun kinematica bestudeerd, en mechanismen worden ontworpen en ontwikkeld. Om de beweging van het chassis te controleren worden bedieningssystemen en elektronica op verschillende niveaus geïmplementeerd.

Le robot mobile autonome : le projet mécanique

L'ébauche d'un robot mobile autonome qui doit être capable de se mouvoir intelligemment et d'exécuter des actions sans l'aide d'un opérateur ou d'un guide, exige l'intégration de différentes technologies. Cela implique que la robotique mobile devient interdisciplinaire et de ce fait un défi captivant. Pour résoudre des problèmes de mouvement, la robotique mobile a besoin de la connaissance de la mécanique, de la cinématique, de la dynamique et de la théorie de contrôle. Des systèmes robustes de perception exigent la connaissance de l'analyse des signaux et du traitement des images par ordinateur ainsi que des technologies de détection. La localisation et la navigation exigent la connaissance des algorithmes informatiques, la théorie d'information, l'intelligence artificielle et la théorie de probabilité.

Le but de cette thèse consiste à développer un mécanisme de mouvement qui est la base d'un robot mobile complet capable de trouver son chemin d'une façon autonome à travers un espace parsemé d'obstacles. Pour accomplir cette tâche, les différents mécanismes de mouvements possibles et leur cinématique ont été étudiés et des mécanismes ont été conçus et développés. Pour contrôler les mouvements du châssis, des systèmes de commande et des systèmes électroniques sur différents niveaux ont été mis en œuvre.

Contents

| | |
|--|-----------|
| Acknowledgements | II |
| Executive Summaries | III |
| 1 Introduction | 1 |
| 1.1 Objectives | 1 |
| 1.2 Overview of the Thesis | 2 |
| 2 Basic Concepts of Design | 3 |
| 2.1 Introduction | 3 |
| 2.2 Problem Statement | 4 |
| 2.3 Definitions of Terms | 5 |
| 2.3.1 Robot | 5 |
| 2.3.2 Mobility | 6 |
| 2.3.3 Autonomous | 7 |
| 2.3.4 Holonomic and Non Holonomic | 7 |
| 3 Wheeled Mobile Robots | 9 |
| 3.1 Introduction | 9 |
| 3.2 The Wheel and Rolling | 11 |
| 3.2.1 Principle of Rolling | 11 |
| 3.2.2 Wheel Classification | 11 |
| 3.3 Wheel Configuration | 14 |
| 3.3.1 Overview | 14 |
| 3.3.2 Summary | 27 |
| 4 Design and Development | 28 |
| 4.1 Concept | 28 |
| 4.1.1 General Dimensions and Robot Shape | 29 |
| 4.1.2 Wheel Configuration and Wheels | 30 |
| 4.1.3 Modularity | 32 |
| 4.2 Energy Supply | 34 |
| 4.2.1 Battery Pack | 34 |
| 4.2.2 Case Study | 36 |
| 4.2.3 Autonomy | 37 |
| 4.2.4 Battery Charger | 38 |
| 4.3 Mechanic design | 39 |
| 4.3.1 Robot's Leg | 40 |
| 4.3.1.1 Driven Steered Standard Wheel | 40 |
| 4.3.1.2 Bearings | 45 |
| 4.3.2 Motors | 46 |
| 4.3.2.1 Drive Motor | 46 |
| 4.3.2.2 Steer Motor | 49 |
| 4.3.3 Frame and Transmission | 53 |

| | | |
|----------|-------------------------------------|-----------|
| 4.3.3.1 | Frame | 53 |
| 4.3.3.2 | Transmission | 55 |
| 4.4 | Electronic design | 58 |
| 4.4.1 | Drive Motor Electronics | 60 |
| 4.4.1.1 | Inputs | 61 |
| 4.4.1.2 | Outputs | 61 |
| 4.4.2 | Steer Motor Electronics | 62 |
| 4.4.2.1 | Inputs | 63 |
| 4.4.2.2 | Outputs | 63 |
| 4.4.3 | Interface Electronics | 64 |
| 4.4.3.1 | Microcontroller | 65 |
| 4.4.3.2 | Voltage Regulation | 65 |
| 4.4.3.3 | Communication and Programming | 66 |
| 4.4.3.4 | Digital to Analogue Converter | 66 |
| 4.4.3.5 | Analogue to Digital Converter | 66 |
| 4.5 | Software design | 67 |
| 5 | Kinematics | 72 |
| 5.1 | Introduction | 72 |
| 5.2 | Kinematics | 73 |
| 5.2.1 | Representing Robot's Position | 73 |
| 5.2.2 | Kinematic Wheel Model | 75 |
| 5.2.3 | Kinematic Robot Model | 76 |
| 5.2.3.1 | Degree of Mobility | 78 |
| 5.2.3.2 | Degree of Steerability | 80 |
| 5.2.3.3 | Degree of Manoeuvrability | 81 |
| 5.2.4 | Synchro Drive | 81 |
| 6 | Conclusions and Further Work | 83 |
| 6.1 | Conclusions | 83 |
| 6.2 | Further Work | 84 |
| | Abbreviations | 85 |
| | List of figures | 86 |
| | References | 88 |
| | Appendix A | |
| | Appendix B | |

1 Introduction

1.1 Objectives

The design of autonomous mobile robots capable of intelligent motion and action involves the integration of many different bodies of knowledge. The aim of this project is to idealise an existing autonomous mobile robot, on all levels. This includes the mechanics, kinematics, dynamics, perception, sensor fusion, localization, path planning and navigation. All these aspects have to be reviewed and modified to a modular system, if necessary new modular modules have to be designed and developed. This way a robust and modular autonomous mobile robot, capable of intelligent motion and performing different tasks will arise. One of its tasks could be winning the 'Melexis Safety Trophy 2006'.

To obtain this aim, the workload is divided between three students. The thesis part of Mark Nelissen is to write anew the software for the robot, making it also modular and as independent of the hardware as possible. This consists of implementing last year's robot software, developed by Jan, Thomas and Bart [4], onto a new and modular framework.

The thesis part of Guillermo Moreno is fully devoted to the development of a modular sensor set up. This is designing the low level electronics and software in charge of both controlling the different sensors hardware and saving the data properly. Also a bus system, aimed at communicating with the on board PC, supporting different sensor modules, is worked out.

This thesis will handle the problems concerning locomotion mechanisms, kinematics, dynamics, and control and operating systems.

1.2 Overview of the Thesis

In ‘chapter 2: Basic Design Concepts,’ some frequently used terms are explained and the general approach to a mechanical design is given.

In order to take notice of the problems in the existing robot, and to be able to idealise, or redesign a locomotion mechanism, a study is needed on the existing state-of-the art locomotion mechanisms. This general study is presented in ‘Chapter 3: Wheeled Mobile Robots.’ Different wheels and wheel configurations are discussed in detail in this chapter.

The next chapter, ‘Chapter 4: Design and Development,’ is dedicated to the design and development of a new locomotion mechanism, and the implementation of its designed and developed electronics and operating software. This is the core chapter of the thesis.

‘Chapter 5: Kinematics,’ deals with the in chapter 4 designed chassis’ kinematics.

Finally, conclusions are made and proposals for future work are enlightened in ‘Chapter 6: Conclusions and Further Work.’

2 Basic Design Concepts

2.1 Introduction

Mechanical engineering design is mainly a creative activity which involves a rational decision making process. Generally speaking, it is directed at the satisfaction of a particular need by means of a mechanical system, whose general configuration, performance specifications and detailed definition conform the ultimate task of the design activity.[7] There is no unified approach or methodology to actually design a system, in so much as there does not exist a unified approach to creativity. Given a particular need, each individual designer would probably design something different. There are however, some common guidelines which can be useful in a very general way. These guidelines are variations of the so called ‘design process’ (Fig.2.1), which is a stepwise description of the main tasks typically developed in a comprehensive design exercise. In any case, one of the main tasks in any design situation is the so called ‘definition of the problem’ or ‘problem statement’.[7]

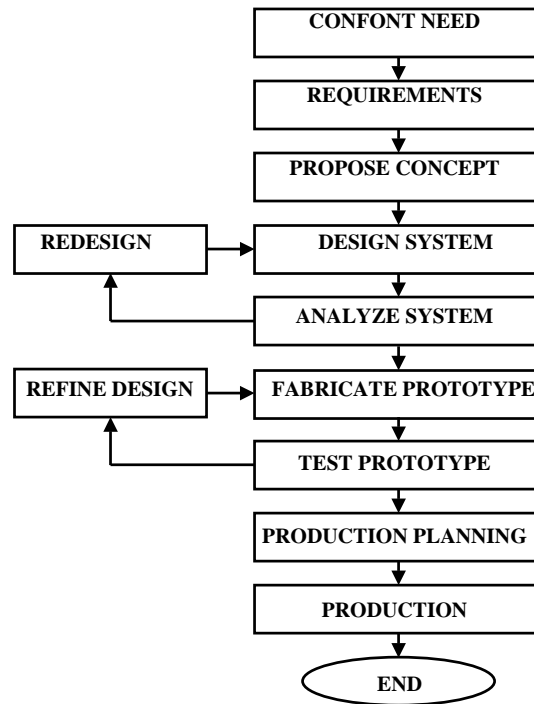

Fig.2.1 A sequential Design Process [7]

2.2 Problem Statement

What are the requirements? This is the main question to solve before designing a mechanism. Wanted here is a robot platform modular in every way, and the possibility to join the ‘Melexis Safety Trophy’ is desirable. To achieve this goal the rules of the contest need to be known. These rules are a serious limitation of the possibilities. A short overview is stated underneath. The challenge of the Melexis Safety Trophy is to develop an autonomous robot that is able to drive safely from point A to point B. The environment is similar to a real traffic situation with lanes, road signs, traffic lights and other vehicles. More details about the concept and

specifications concerning the dimensions of tracks, lanes, road signs and obstacles can be found in [5]. The robot's most important specifications at this point are:

- Maximum and minimum dimensions; there is no maximal length, the width has to be between $200mm$ and $450mm$ and the maximum height is $500mm$.
- Drive; only electrical power is authorized, so no combustion engines may be used.
- Locomotion; all robots need to use wheels. These wheels need to be big enough to cope with small irregularities of the floor.
- Cost; the robot may not cost more than €2500. Borrowed or sponsored parts count for their replacement value with exception of one personal computer or laptop and one car battery, because these can be reused.

In order to construct a conform wheeled autonomous robot, some design decisions have to be made. Before decisions can be made some terms have to be explained.

2.3 Definitions of Terms

2.3.1 Robot

A robot can be defined as 'a mechanical device which performs automated tasks, either according to direct human supervision, a pre-defined program or, a set of general guidelines, using artificial intelligence techniques.' [1],[8] The first commercial robot was developed in 1961 and used in the automotive industry by Ford. The robots were principally intended to replace humans in monotonous, heavy and hazardous processes. Nowadays, stimulated by economic reasons, industrial robots are intensively used in a very wide variety of applications. Most of the industrial robots are stationary. They operate from a fixed position and have limited operating range. The surrounding area of the robot is usually designed in function of

the task of the robot and then secured from external influences. These robots efficiently complete tasks such as welding, drilling, assembling, painting and packaging.

However, in many applications it can be useful to build a robot which can operate with larger mobility. In contrast to most stationary robots, where the surrounding space is adapted to suit the robot tasks, mobile robots have to adapt their behaviour to their surroundings. Instead of performing a fixed sequence of actions, mobile robots need to develop some awareness of their environment through interaction with all kind of sensors; they use on-board intelligence to determine the best action to take. The development of intelligent navigation systems on mobile robots, which ensures efficient and collision free movement, is still the centre of several research projects. [1]

2.3.2 Mobility

Mobile robots are generally those robots which can move from place to place across the ground. Mobility give a robot a much greater flexibility to perform new, complex, exciting tasks. The world does not have to be modified to bring all needed items within reach of the robot. The robots can move where needed. Fewer robots can be used. Robots with mobility can perform more natural tasks in which the environment is not designed specially for them. These robots can work in a human centred space and cooperate with men by sharing a workspace together.[9]

A mobile robot needs locomotion mechanisms that enable it to move unbounded throughout its environment. There is a large variety of possible ways to move which makes the selection of a robot's approach to locomotion an important aspect of mobile robot design. Most of these locomotion mechanisms have been inspired by their biological counterparts which are adapted to different environments and purposes.[9],[10] Many biologically inspired robots walk, crawl, slither, and hop.

2.3.3 Autonomous

An autonomous robot is capable of detecting objects by means of sensors or cameras and of processing this information into movement without a remote control.

2.3.4 Holonomic and Non Holonomic

In mobile robotics the terms omnidirectional, holonomic and non holonomic are often used, a discussion of their use will be helpful.[9]

The terms holonomic and omnidirectional are sometimes used redundantly, often to the confusion of both. Omnidirectional is a poorly defined term which simply means the ability to move in any direction. Because of the planar nature of mobile robots, the operational space they occupy contains only three dimensions which are most commonly thought of as the x , y global position of a point on the robot and the global orientation, θ , of the robot. Whether a robot is omnidirectional is not generally agreed upon whether this is a two-dimensional direction, x , y or a three-dimensional direction, x , y , θ .

In this context a non holonomic mobile robot has the following properties:

- The robot configuration is described by more than three coordinates. Three values are needed to describe the location and orientation of the robot, while others are needed to describe the internal geometry.
- The robot has two DOF, or three DOF with singularities. (One DOF is kinematically possible but is it a robot then?)

In this context a holonomic mobile robot has the following properties:

- The robot configuration is described by three coordinates. The internal geometry does not appear in the kinematic equations of the abstract mobile robot, so it can be ignored.

- The robot has three DOF without singularities.
- The robot can instantly develop a wrench in an arbitrary combination of directions x , y , θ .
- The robot can instantly accelerate in an arbitrary combination of directions x , y , θ .

Non holonomic robots are most prevalent because of their simple design and ease of control. By their nature, non holonomic mobile robots have fewer degrees of freedom than holonomic mobile robots. These few actuated degrees of freedom in non holonomic mobile robots are often either independently controllable or mechanically decoupled, further simplifying the low-level control of the robot. Since they have fewer degrees of freedom, there are certain motions they cannot perform. This creates difficult problems for motion planning and implementation of reactive behaviours.

Holonomic however, offer full mobility with the same number of degrees of freedom as the environment. This makes path planning easier because there aren't constraints that need to be integrated. Implementing reactive behaviours is easy because there are no constraints which limit the directions in which the robot can accelerate.

3 Wheeled Mobile Robots

3.1 Introduction

Before we design and develop our own locomotion mechanism, we have to study the existing mechanisms and compare their benefits and disadvantages.

Although a lot of locomotion mechanisms have been inspired by their biological counterparts, nature did not develop a fully rotating, actively powered joint, which is the technology necessary for wheeled locomotion. This mechanism is not completely foreign to biological systems. Our bipedal walking system can be approximated by a rolling polygon, with sides equal in length d to the span of the step, shown in Fig.3.1.[10] As the step size decreases, the polygon approaches a circle or wheel. In general, legged locomotion requires higher degrees of freedom and therefore greater mechanical complexity than wheeled locomotion.[9]

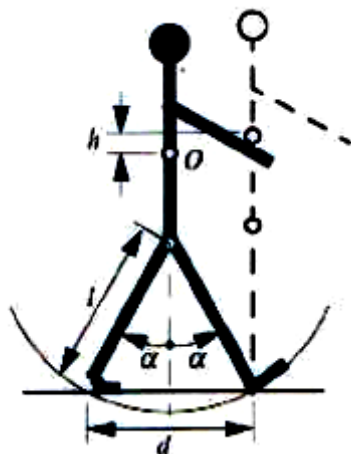

Fig.3.1

A bipedal walking system can be approximated by a rolling polygon, with sides equal in length d to the span of the step. As the step size decreases, the polygon approaches a circle or wheel with radius l .

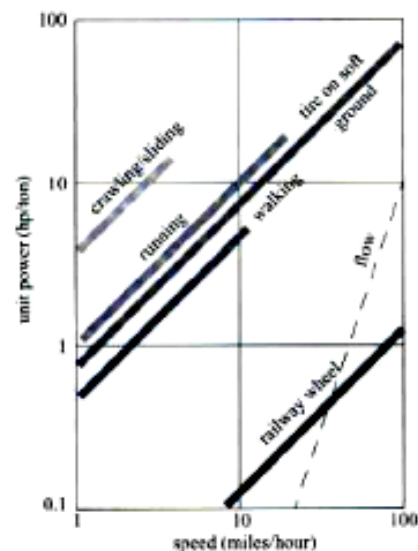

Fig.3.2

Specific power versus attainable speed of various locomotion mechanisms

The wheel has been by far the most popular locomotion mechanism in mobile robotics and in man-made vehicles in general. It can achieve very good efficiencies, as demonstrated in Fig.3.2 [10], and does so with a relatively simple mechanical implementation. Wheels are extremely well suited for flat surfaces where this type of locomotion is more efficient than a legged one. For example the railway is ideally engineered for wheeled locomotion because rolling friction is minimized on a hard and flat steel surface. When the surface becomes soft, wheeled locomotion accumulates inefficiencies due to rolling friction whereas legged locomotion suffers much less because it consists only of point contacts with the ground. This dramatic loss of efficiency in the case of a tire on soft ground is also shown in Fig.3.2. [10] Nature favours legged locomotion, because of its rough and unstructured terrain. In contrast the human environment frequently consists of engineered, smooth surfaces, both indoors and outdoors. Therefore virtually all industrial applications of mobile robotics utilize some form of wheeled locomotion. In this thesis we shall not delve in the theory concerning legged robots. We will however explain the wheel theory in more detail since there is a very large space of possible kinds of wheels and their configurations when one considers possible techniques for mobile robot locomotion.

3.2 The Wheel and Rolling

3.2.1 Principle of Rolling

A wheel (as used here) is rotationally symmetric about its principal or roll axis and rests on the ground on its contact patch. The contact patch is a small area which is in frictional contact with the ground such that the forces required to cause relative sliding between the wheel and ground are large for linear displacements and small for rotational motions. Thus, we assume that a wheel undergoing pure rolling has a contact point with no slip laterally or longitudinally, yet is free to twist about the contact point. [9]

The kinematic constraint of rolling is called a higher-pair joint. The kinematic pair has two constraints so that two degrees of freedom are lost by virtue of the rolling constraint.

3.2.2 Wheel Classification

There are three major wheel classes. They differ widely in their kinematics, and therefore the choice of wheel type has a large effect on the overall kinematics of the mobile robot. The choice of wheel types for a mobile robot is strongly linked to the choice of wheel arrangement, or wheel geometry. The mobile robot designer must consider these two issues simultaneously when designing the locomotion mechanism of a wheeled robot.

First of all there is the standard wheel as shown in Fig.3.3. This is what most people think of when asked to picture a wheel. The standard wheel has a roll axis parallel to the plane of the floor and can change orientation by rotating about an axis normal to the ground through the contact point. The standard wheel has two DOF. A fixed

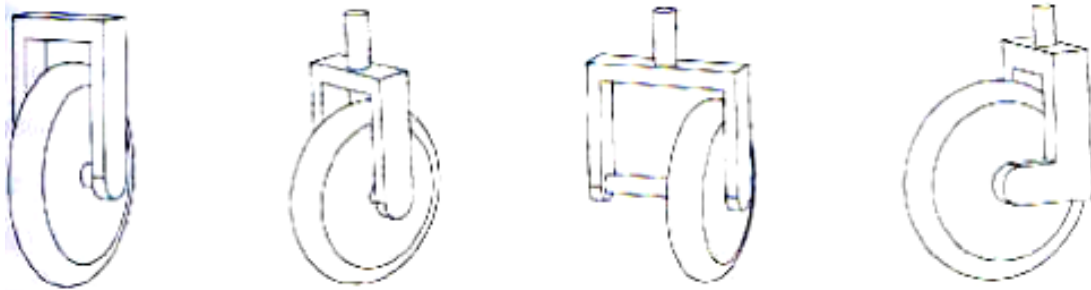

Fig.3.3
Standard Wheels, from left to right: Fixed, Steered, Lateral Offset, Castor

standard wheel is mounted directly to the robot body. When the wheel is mounted on a rotational link with the axis of rotation passing through the contact point, we speak of a steered standard wheel. A variation which reduce rotational slip during steering is called the lateral offset wheel. The wheel axis still intersects the roll axis but not at the contact point. The caster offset standard wheel, also know as the castor wheel, has a rotational link with a vertical steer axis skew to the roll axis. The key difference between the fixed wheel and the castor wheel is that the fixed wheel can accomplish a steering motion with no side effects, as the centre of rotation passes through the contact patch with the ground, whereas the castor wheel rotates around an offset axis, causing a force to be imparted to the robot chassis during steering.[9],[10]

The second type of wheel is the omnidirectional wheel. This is a disk with a multitude of conventional standard wheels mounted on its periphery as shown in Fig.3.4.[9] The omnidirectional wheel has tree DOF and functions as a normal wheel, but provides low resistance in another direction as well. The angle of the peripheral wheels may be changed to yield different properties. The small rollers attached around the circumference of the wheel are passive and the wheel's primary axis serves as the only actively powered joint. The key advantage of this design is that, although the wheel rotation is powered only along the one principal axis, the



Fig.3.4
Omnidirectional Wheels, form left to right: Universal, Double Universal, Swedish 45°

wheel can kinematically move with very little friction along many possible trajectories, not just forward and backward.[10]

The third type of wheel is the ball or spherical wheel. It has also three DOF. The spherical wheel is a truly omnidirectional wheel, often designed so that it may be actively powered to spin along any direction. There have not been many attempts to build a mobile robot with ball wheels because of the difficulties in confining and powering a sphere. One mechanism for implementing this spherical design imitates the computer mouse, providing actively powered rollers that rest against the top surface of the sphere and impart rotational force.[9][10]

3.3 Wheel Configuration

3.3.1 Overview

The wheel type and wheel configuration are of tremendous importance, they form an inseparable relation and they influence three fundamental characteristics of a: manoeuvrability, controllability, and stability. In general there is an inverse correlation between controllability and manoeuvrability.

The most popular wheel configurations are illustrated with an example below. The used symbols are explained in Fig.3.5. The number of wheels rise from two to four or more. A brief influence on stability, controllability and manoeuvrability is given too.

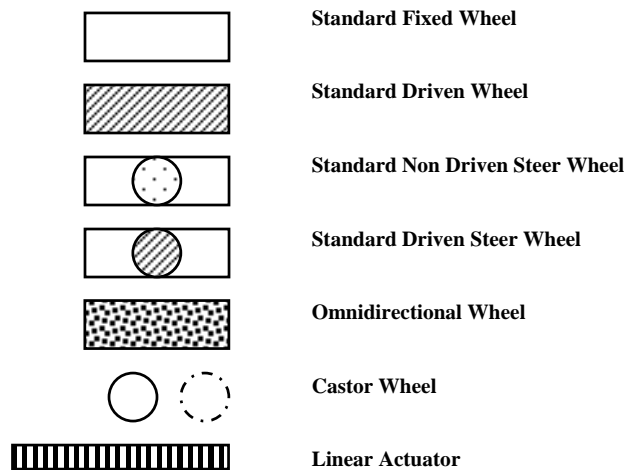

Fig.3.5
Legende

Wheel configurations with two wheels are shown in Fig.3.6 and Fig.3.7 and in Fig.3.8 and Fig.3.9. The first two-wheeled configuration is similar to the mechanism of bikes, and motorcycles. At the front there is a steer wheel which enables the change in orientation, and at the rear a powered drive wheel is mounted. This configuration leads to a static instability when the mechanism is not driven.

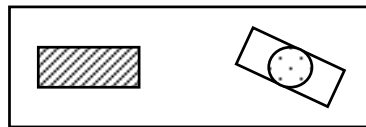

Fig.3.6
Static unstable two-wheeled configuration



Fig.3.7
Bike

Surprisingly, the minimum number of wheels required for static stability is two. As shown in Fig.3.8, a two-wheel differential drive robot can achieve static stability if the centre of mass is below the wheel axle. However, under ordinary circumstances such a solution requires wheel diameters that are impractically large. A commercial mobile robot that uses this wheel configuration is shown in Fig.3.9.

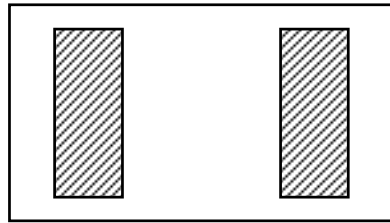

Fig.3.8
 Static stable two-wheeled configuration, if the centre
 of mass is below the wheel axle



Fig.3.9
 Cye, a commercial two-wheel differential-drive robot

Conventionally, static stability requires a minimum of three wheels, with the additional condition that the centre of gravity must be contained within the triangle formed by the ground contact points of the wheels.

The differential drive is a two-wheeled drive system with independent actuators for each wheel. The name refers to the fact that the motion vector of the robot is sum of the independent wheel motions, something that is also true of the mechanical differential. The drive wheels are usually placed on each side of the robot. A non driven wheel, often a castor wheel, forms a tripod-like support structure for the body of the robot. Unfortunately, castors can cause problems if the robot reverses its direction. Then the castor wheel must turn half a circle and, in the process, the offset swivel can impart an undesired motion vector to the robot. This may result in to a translation heading error. Straight line motion is accomplished by turning the drive wheels at the same rate in the same direction. That is not as easy as it sounds. In

place rotation is done by turning the drive wheels at the same rate in the opposite direction. Arbitrary motion paths can be implemented by dynamically modifying the angular velocity and/or direction of the drive wheels. The benefits of this wheel configuration is its simplicity. A differential drive system needs only two motors, one for each drive wheel. Often the wheel is directly connected to the motor with internal gear reduction. The robot described in [1],[2],[3] and [4] has this wheel configuration. Despite its simplicity, the controllability is rather difficult. Especially to make a differential drive robot move in a straight line. Since the drive wheels are independent, if they are not turning at exactly the same rate the robot will veer to one side. Making the drive motors turn at the same rate is a challenge due to slight differences in the motors, friction differences in the drive trains, and friction differences in the wheel-ground interface. To ensure that the robot is travelling in a straight line, it may be necessary to adjust the motor speed very often. This may require interrupt-based software and assembly language programming. It is also very

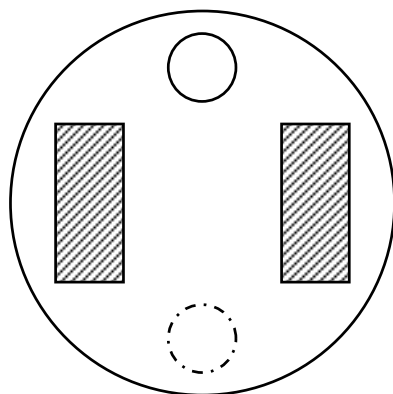

Fig.3.10
Differential drive configuration with two drive wheels and a castor wheel

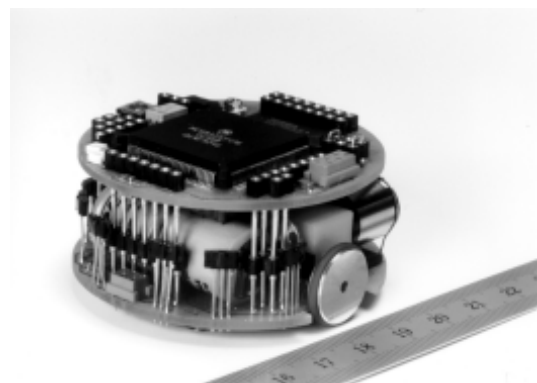

Fig.3.11
Khepera, a small differential drive robot

important to have accurate information on wheel position. This usually comes from the encoders. A round shape differential drive configuration is shown in Fig.3.10. An other three-wheel configuration is the tri-cycle drive, shown in Fig.3.11 and Fig.3.13. The difference between these two mechanisms are the way they steer and drive. The first tri-cycle drive has a non driven steer wheel at the front/rear to change orientation. The drive wheels are at the rear/front of the vehicle. A differential is necessary when the wheels can not slip to avoid mechanical destruction. The second tri-cycle drive has a combined steer and drive mechanism at the front/rear. Two free wheels are mounted on the structure at the rear/front to maintain stability. It is up to the robot designer to decide. Both possibilities have there benefits and disadvantages. It is difficult to find a small differential, but it is also difficult to build a mechanism that steers and drives at the same time. The tri-cycle drive has some serious disadvantages common to the car drive configuration, those are explain later.

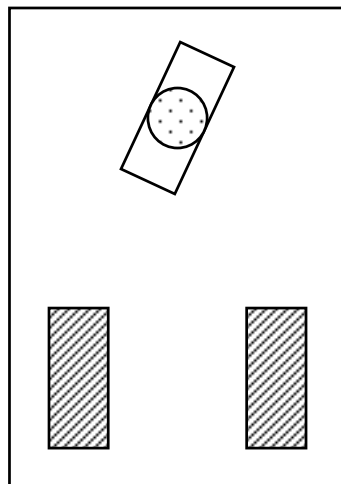

Fig.3.12
Tri-cycle drive, front/rear steering and rear/front driving



Fig.3.13
Piaggio mini truck

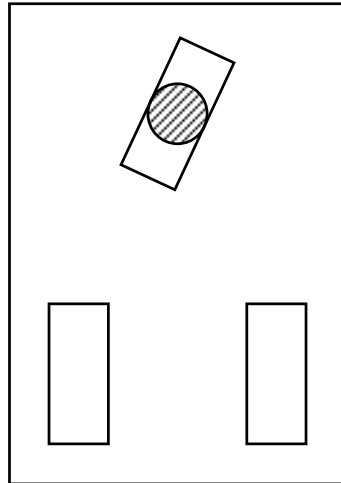

Fig.3.14
Tri-cycle drive, combined steering and driving.

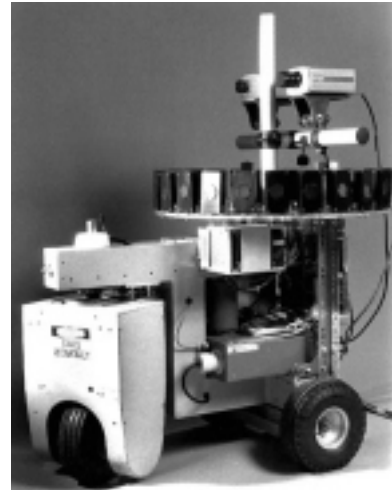

Fig.3.15
Neptune

Another three wheel configuration is the synchro drive. The synchro drive system is a two motor drive configuration where one motor rotates all wheels together to produce motion and the other motor turns all wheels to change direction. Using separate motors for translation and wheel rotation guarantees straight line translation when the rotation is not actuated. This mechanical guarantee of straight line motion is a big advantage over the differential drive method where two motors must be dynamically controlled to produce straight line motion. There is no need for interrupt based control as in the case of differential drive method. Arbitrary motion paths can be done by actuating both motors simultaneously. The mechanism which permits all wheels to be driven by one motor and turned by another motor is fairly complex. Wheel alignment is critical in this drive system, if the wheels are not parallel, the robot will not translate in a straight line. In Fig.3.16 the synchro drive wheel configuration is shown. Fig.3.17 shows MRV4 a robot with this drive mechanism.

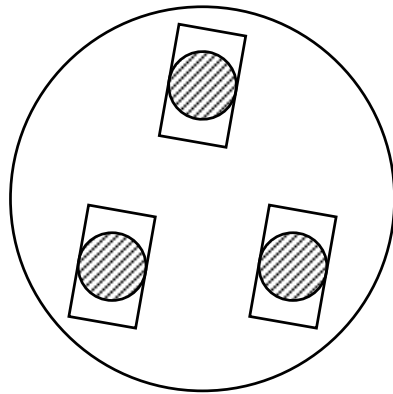

Fig.3.16
Synchro drive wheel configuration.



Fig.3.17
MRV4 robot with synchro drive mechanism

In order to improve stability the synchro drive system can be used with four wheels as well.

Generally stability can be further improved by adding more wheels, although once the number of contact points exceeds three, the hyper static nature of the geometry will require some form of flexible suspension on uneven terrain to maintain wheel contact with the ground. One of the simplest approaches to suspension is to design flexibility into the wheel itself. For instance, in the case of some four wheeled indoor robots that use castor wheels, manufacturers have applied a deformable tire of soft rubber to the wheel to create a primitive suspension. Of course, this limited solution cannot compete with a sophisticated suspension system in applications where the robot needs a more dynamic suspension for significantly non flat terrain.

In addition, balance is not usually a research problem in wheeled robot designs, because wheeled robots are almost always designed so that all wheels are in ground contact at all times. Instead of worrying about balance, wheeled robot research tends

to focus on the problems of traction and stability, manoeuvrability, and control. Can the robot wheels provide sufficient traction and stability for the robot to cover all of the desired terrain, and does the robot's wheeled configuration enable sufficient control over the velocity of the robot?

Consider the car type locomotion or Ackerman steering configuration used in automobiles. It is very common in the 'real world,' but not as common in the 'robot world.' The properties of the tri cycle drive are similar. Such a vehicle typically has a turning diameter that is larger than the car. Furthermore, for such a vehicle to move sideways requires a parking manoeuvre consisting of repeated changes in direction forward and backward. The limited manoeuvrability of Ackerman steering has an important advantage: its directionality and steering geometry provide it with very good lateral stability in high-speed turns. The path planning is much more difficult. Note that the difficulty of planning the system is relative to the environment. On a highway, path planning is easy because the motion is mostly forward with no absolute movement in the direction for which there is no direct actuation. However, if the environment requires motion in the direction for which there is no direct actuation, path planning is very hard. Ackerman steering and its cousin, tricycle steering is characterized by a pair of driving wheels and a separate pair of steering wheels (only a single steering wheel in tricycle locomotion as discussed above). In Fig.3.18 a front wheel driven car drive is pictured. Its main concurrent is the rear wheel driven car drive configuration and is shown in Fig.3.29. The differences between these two kinds of Ackerman steering mechanisms are the same as the differences between the two tri cycle drives explained a few paragraphs back in this section. An advantage of front wheel drive is a smaller turning radius. However in automobiles we see often the opposite. The construction of this combined drive and steer train has great complexity.

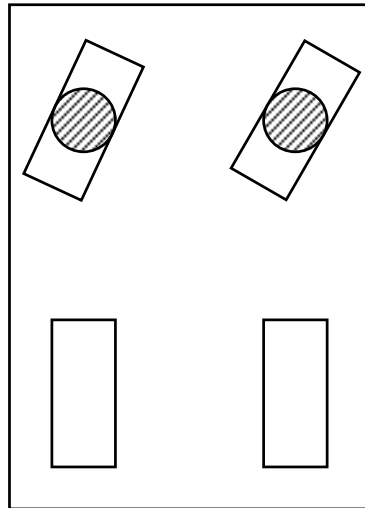

Fig.3.18
Front driven/steered Ackerman steering

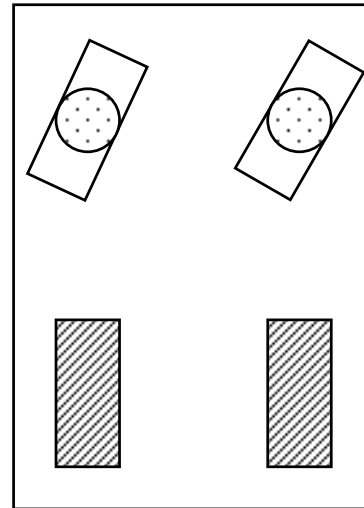

Fig.3.19
Front steered/rear driven Ackerman steering

A car type drive is one of the simplest locomotion systems in which separate motors control translation and turning this is a big advantage compared to the differential drive system. There is one condition: the turning mechanism must be precisely controlled. A small position error in the turning mechanism can cause large odometry errors. This simplicity in in line motion is why this type of locomotion is popular for human driven vehicles.

Articulated drive, as in Fig3.21, is similar to the car type drive except the turning mechanism is a deformation in the chassis of the vehicle, not pivoting of wheels. By deforming the chassis the forces act on the chassis, not on the steer train. This design has the same disadvantages of the car-type drive. If multiple wheels are driven and a differential is not used, wheel slippage will occur. This design is commonly used in construction equipment (Fig3.22) where wheel slippage is not an issue because the speeds are slow and the coefficient of friction with the ground is low. This type uses

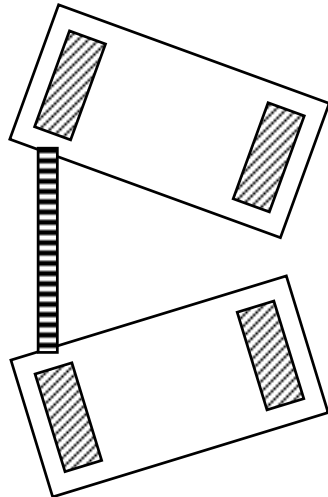

Fig.3.21
Articulated drive configuration.



Fig.3.22
Construction worker with articulated drive.

one motor to drive the wheels and one actuator to change the pivot angle of the chassis.

In the wheel configurations discussed above, we have made the assumption that wheels are not allowed to skid against the surface. An alternative form of steering, termed slip/skid, may be used to reorient the robot by spinning wheels that are facing the same direction at different speeds or even opposite directions. There is no explicit steering mechanism. Below in Fig.3.23 the mechanism is pictured. Skid-steer locomotion is commonly used on tracked vehicles such as tanks and bulldozers, but is also used on some four- and six-wheeled vehicles. The Nanokhod (Fig.3.24) is an example of a mobile robot based on the same concept. Robots that make use of tread have much larger ground contact patches, and this can significantly improve their manoeuvrability in loose terrain compared to conventional wheeled designs. However, due to this large ground contact patch, changing the orientation of the robot usually requires a skidding turn, wherein a large portion of the track must slide against the terrain. The disadvantage of such configurations is coupled to the slip/skid steering. Because of the large amount of skidding during a turn, the exact

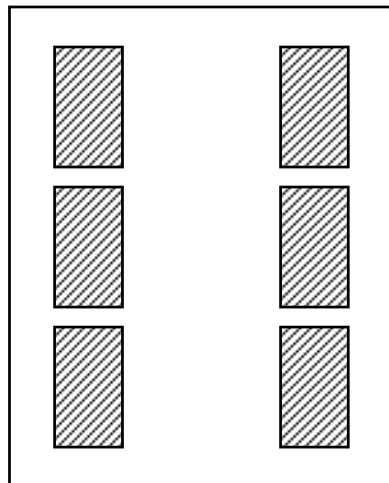

Fig.3.23
Slip/skid wheel configuration.

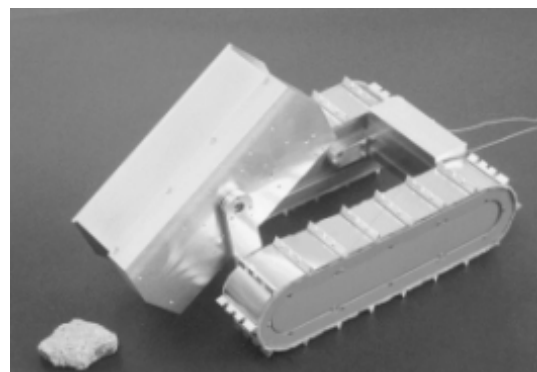

Fig.3.24
Nanokhod, an autonomous robot with tracks.

centre of rotation of the robot is hard to predict and the exact change in position and orientation is also subject to variations depending on the ground friction. Controlling straight line travel can be difficult to achieve. Therefore, dead reckoning on such robots is highly inaccurate. This is the trade off that is made in return for extremely good manoeuvrability and traction over rough and loose terrain. Furthermore, a slip/skid approach on a high-friction surface can quickly overcome the torque capabilities of the motors being used. In terms of power efficiency, this approach is reasonably efficient on loose terrain but extremely inefficient otherwise.

Some robots are omnidirectional, meaning that they can move at any time in any direction along the ground plane (x, y) regardless of the orientation of the robot around its vertical axis. This level of manoeuvrability requires omnidirectional wheels which presents manufacturing challenges. Omnidirectional movement is of great interest for complete manoeuvrability. Omnidirectional robots that are able to move in any direction (x, y, θ) at any time are also holonomic as discussed in chapter

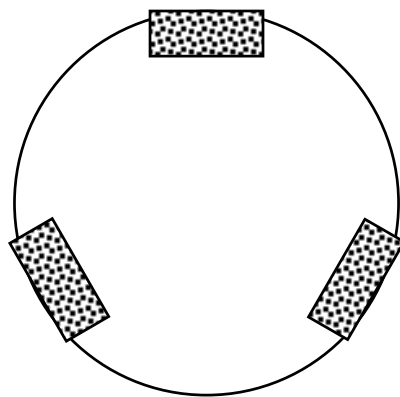

Fig.3.25
Omnidirectional configuration with three spherical wheels



Fig.3.26
Robot with three omnidirectional wheels

two. Two examples of such homonymic robots are presented below. The first omnidirectional wheel configuration has three spherical wheels each actuated by one motor, and there are placed in an equilateral triangle as depicted in Fig.3.26. This concept provides excellent manoeuvrability and is simple in design however, it is limited to flat surfaces and small loads, and it is quite difficult to find round wheels with high friction coefficients. In general, the ground clearance of robots with Swedish and spherical wheels is somewhat limited due to the mechanical constraints of constructing omnidirectional wheels. The second omnidirectional wheel configuration has four spherical wheels each driven by a separate motor. This omnidirectional arrangement depicted in Fig.3.27 and Fig.3.28 has been used successfully on several research robots. By varying the direction of rotation and relative speeds of the four wheels, the robot can be moved along any trajectory in the plane and, even more impressively, can simultaneously spin around its vertical axis. For example, when all four wheels spin ‘forward’ or ‘backward’ the robot as a

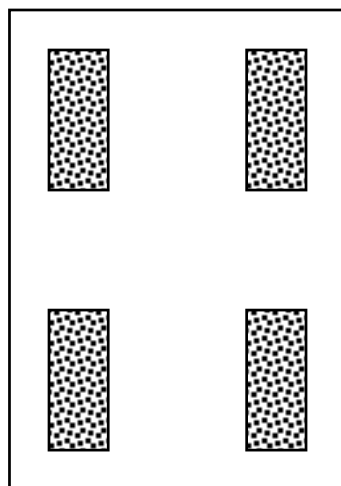

Fig.3.27
Omnidirectional configuration with four spherical wheels

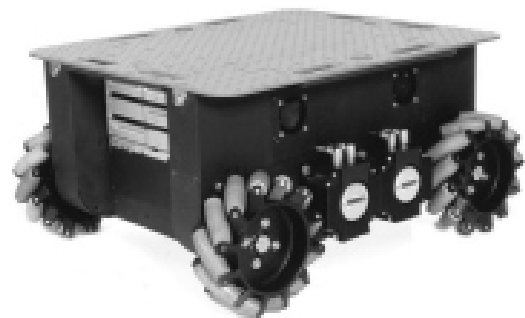

Fig.3.28
Uranus, a four omnidirectional wheeled robot

whole moves in a straight line forward or backward, respectively. However, when one diagonal pair of wheels is spun in the same direction and the other diagonal pair is spun in the opposite direction, the robot moves laterally. This omnidirectional wheel arrangement are not minimal in terms of control motors.

Even with all the benefits, few holonomic robots have been used by researchers because of the problems introduced by the complexity of the mechanical design and controllability.

3.3.2 Summary

En summary, there is no ‘ideal’ drive configuration that simultaneously maximizes stability, manoeuvrability, and controllability. Each mobile robot application places unique constraints on the robot design problem, and the designer’s task is to choose the most appropriate drive configuration possible from among this space of compromises. In the next chapter we will choose one wheel configuration and work out a fully locomotion mechanism.

4 Design and Development

4.1 Concept

Before designing and developing a new robot platform, we will repeat our requirements and our limitations. We want to build an autonomous mobile robot, which will be used for different tasks in an indoor environment, and we must keep in mind the possibility to join the ‘Melexis Safety Trophy.’ With the knowledge we picked up in the previous chapters, we can design a new mechanical platform conform our requirements that forms the base of the entire robot.

The robot is represented as a black box shown in Fig.4.1. In the first stage of the design process the content of the black box is unknown. We just want the robot to fulfil its tasks. Step by step we will refine the design and work out each different module in the black box. The result, the final mechanical platform is also shown in Fig.4.1.

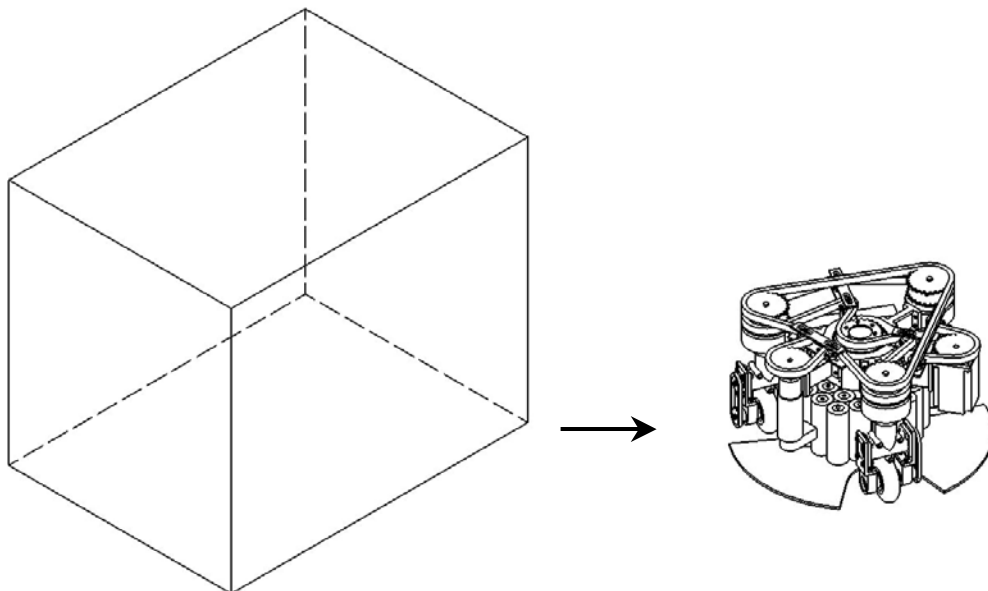

Fig.4.1

Black box analogy and final mechanical platform

4.1.1 General Dimensions and Robot Shape

When the robot is desired to join the ‘Melexis Safety Trophy,’ the main limitations are the dimensions and the cost of the robot. The maximum and minimum dimensions are stated here:

- The maximum length L_{\max} is not determined.
- The maximum width W_{\max} is $450mm$.
- The minimum width W_{\min} is $200mm$.
- The maximum height H_{\max} is $500mm$.

The shape of a mobile robot is of great importance and can have an impact on the robots performance. For instance in Fig.4.2 a square and a cylindrical robot with identical width are moving from left to right. The square robot has a greater risk of being trapped by an obstacle or failing to find its way through a narrow space. The cylindrical robot can use a simple algorithm to find its way through the narrow passage because it is able to rotate in front of the obstacle without getting trapped. The square robot must back up first and rotate afterwards and even then it is uncertain the robot is not getting trapped. Since we want to use the robot for different tasks and the robot will run autonomously, a cylindrical shaped robot is the best solution. The black box considering the general dimensions and the shape is shown in Fig.4.3.

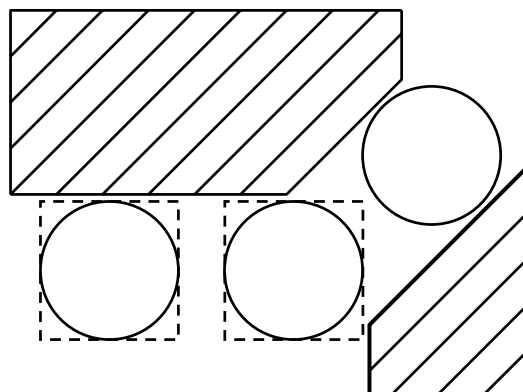

Fig.4.2

Cylindrical versus square robot shape

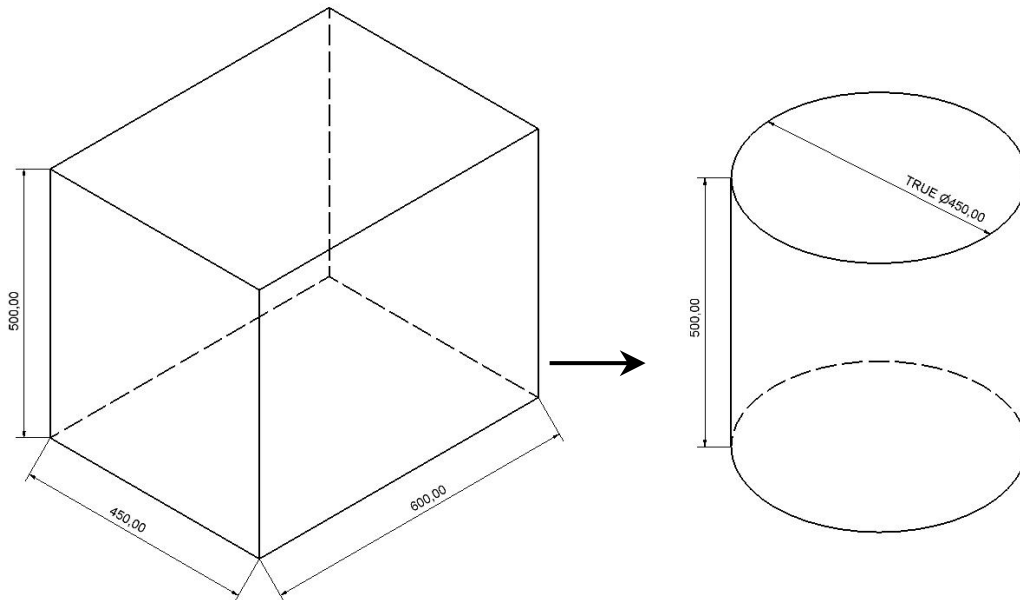

Fig.4.3

Black box analogy considering general dimensions and shape.

4.1.2 Wheel Configuration and Wheels

The next step in the design process is the choice of a wheel configuration and the wheel types used in this wheel configuration. In chapter 3 an overview of possible wheel configurations is given.

We decide to take a three wheeled synchro drive principle with standard steered wheels. The standard wheels are chosen because of their simplicity and they available in all sizes and shapes. In contrast omnidirectional wheels are complex and hard to find.

The three wheeled synchro drive principle has some benefits with respect to other wheel configurations, in this application. The main benefits:

- Only two motors are necessary; one motor rotates all wheels together to produce motion, the other motor turns all wheels to change direction.
- No suspension needed; the three wheel configuration ensures the ground contact of each wheel.
- The mechanical guarantee of straight line motion.
- The omnidirectional behaviour. The robot can move to a certain position, and rotate in place to achieve a certain orientation.
- Possibility of symmetric design.

The main disadvantages:

- Complex mechanism which permits all wheels to be driven by one motor and turned by another motor.
- Wheel alignment has to be precisely set to guarantee straight line motion.

There is however one problem with this configuration as we shall see in chapter 5. In fact the robot chassis can only move from point to point and is not able to change its orientation. If we want the robot to view the entire surrounded environment, we have to equip the robot with a 360 degree sensor casing or hull.

4.1.3 Modularity

We decide to separate the robot into two parts as indicated in Fig.4.4. The inner cylinder is the lower part of the robot which will become the mechanical platform and is worked out further in this chapter. The bigger, surrounding cylinder will be referred to as the upper part of the robot and will be the platform which can contain the equipment needed to fulfil a desired robot task. In this way modularity is introduced in the design phase. In our case the latter platform holds the computer, camera, sensors and specific electronics and is mechanically coupled to the steering motor. This means that when the steering motor is changing the orientation of the wheels it changes the orientation of the upper platform identically.

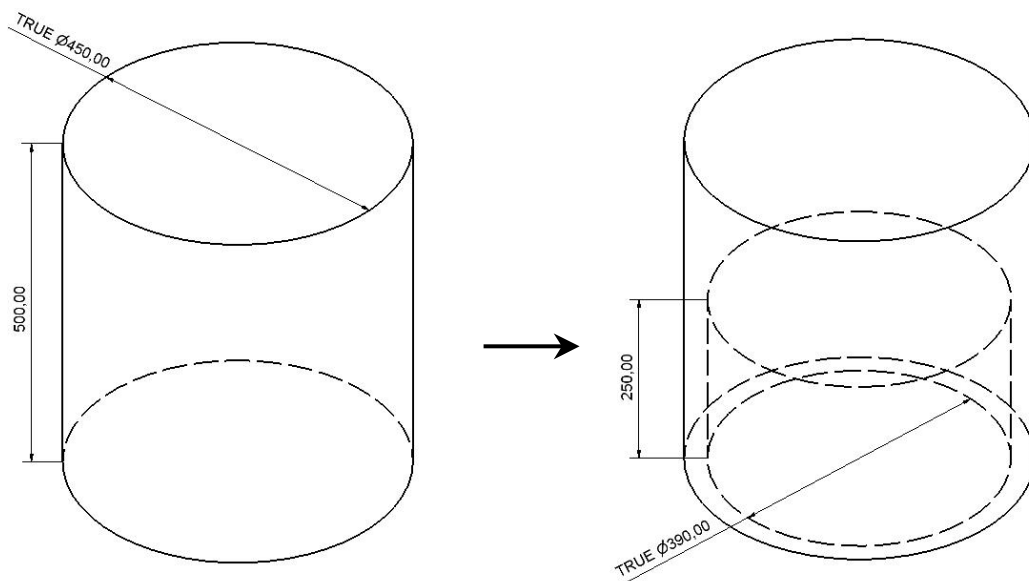

Fig.4.4

Black box analogy, upper and lower platform

Now, to avoid a 360 degree sensor casing , we choose a simpler form, for example a 180 degree sensor casing, and attach it to the upper platform with an alignment in the direction of motion, parallel with the wheels. This simplification avoids the more expensive and more complicated 360 degree without losing too much of the robots

view. Although it might seem that the 360 degree sensor gives an overview of the whole surrounding area, these images will still be fragmented and jump from one sensor to the next which make image building quite a difficult task. By using the 180 degree sensor and aligning it with the wheels, a clear picture of the whole area is yielded, just by rotating the robot around its axis. (Fig.4.5)

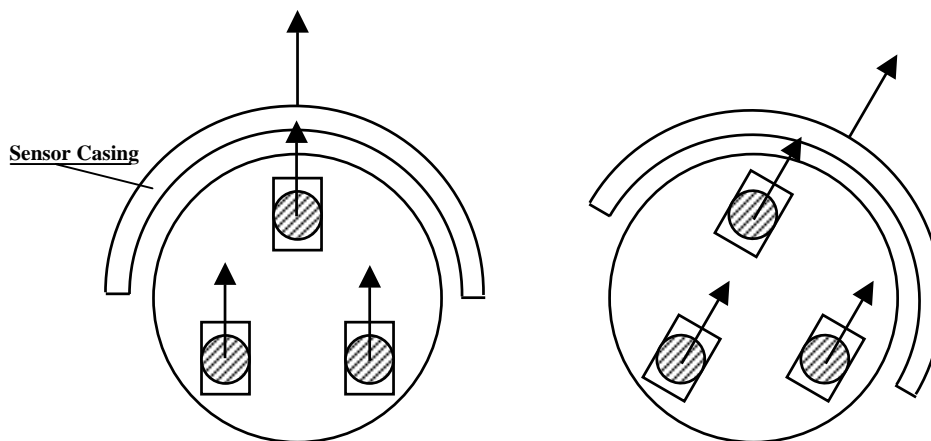

Fig.4.5
Synchro drive with attached sensor casing

In this application the upper platform contains a computer. A normal motherboard of a PC with a PCI card on it is about 200mm high. This means that the upper platform needs a height of 250mm to make sure the computer fits.

The sensors of the robot are sensors of the same type as used in previous work [1],[2],[3] and [4]. These sensors and their specific wires and connections can be placed in a 20mm deep housing. We decide to leave a 30mm wide shaft around the mechanical platform to allow the sensor casing to move. The new dimensional limitations are also shown in Fig.4.4.

4.2 Energy Supply

With this concept in mind, we can design the lower or mechanical platform. This platform needs an energy supply to be able to perform tasks autonomously. Since combustion engines are expelled of the ‘Melexis Safety Trophy’ we are forced to use electrical energy. This energy is stored in accumulators or batteries. In fact there is a difference between these terms, the first ones are rechargeable, the others are not. In this thesis the terms are used redundantly, and we assume rechargeable batteries.

Choosing a battery configuration is a key feature in the design process. Actually this is an iterative process. The dimensions, voltage, weight and recharge method of the battery configuration form restrictions on the entire design process and determine directly the autonomy of the robot.

4.2.1 Battery Pack

To achieve our requirements on energy supply we decide to make our own battery pack. That way we can design a symmetric battery pack and increase the stability of the robot. To increase the stability of the robot the centre of gravity should be located as low as possible and on the normal axis through the centre of gravity of the triangle formed by the three contact points of the wheels to the ground. The batteries make an important contribution to the robots weight which we want to keep as low as possible.

Nowadays a popular voltage seems to be 12V, used in automobiles and lots of other applications. However, in the future the automobile industry intends to rise the voltage from 12V to 24V or even to 36V because of the spectacular rise of electronics in cars. We take 24V as an appeasement voltage.

A battery must meet certain performance goals. These goals include: quick discharge and recharge capability, long cycle life (the number of discharges before becoming unserviceable), low costs, recyclable, high specific energy (amount of usable energy, measured in watt hours per kilogram), high energy density (amount of energy stored per unit volume), specific power, and the ability to work in wide temperature range. No battery currently available meets all these criteria.

However 'Nickel Metal Hydride' (NiMH) batteries fulfil this conditions quite well. They have a high specific energy: around $90Wh/kg$. Only 'Lithium Ion' batteries score better with a specific energy around $150Wh/kg$. But 'Lithium Ion' batteries are very expensive, and hard to charge, a control unit is desirable. 'Nickel Cadmium' (NiCd) batteries are very similar to NiMH batteries. Both types of batteries have higher specific energy and higher energy density than advanced 'Lead Acid' batteries. In Fig.4.6. a battery pack existing of twenty NiMH cells is shown.

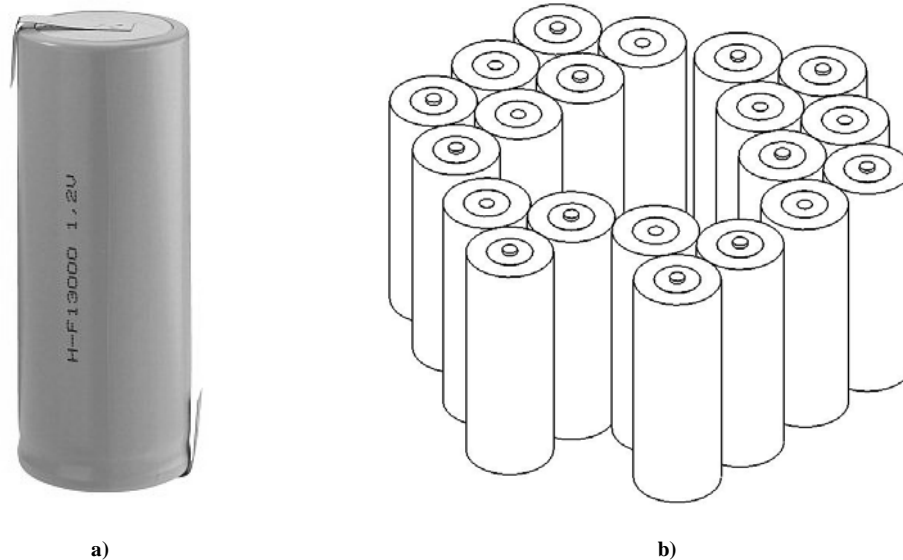

Fig.4.6

- a) NIMH SPECIALE ACCU 13000F-1Z
- b) Battery pack with twenty cells

The cell's specifications are:

- Nickel Metal Hydride
- 1.2V
- 13000mAh
- 230g
- height 89mm, diameter 32.5mm

The entire battery pack's specifications are:

- $20 \times 1.2V = 24V$ (4.1)

- 13000mAh

- $24V \times 13000mAh = 312Wh$ (4.2)

- $20 \times 290g = 5.8kg$ (4.3)

- specific energy; $\frac{312}{5.8} = 54kWh/kg$ (4.4)

- energy density; $\frac{312}{20 \times 0.089 \times 0.01625^2 \times \pi} = 211kWh/m^3$ (4.5)

- the specific arrangement of the cells will become clear in the rest of this chapter.

4.2.2 Case Study

Let us compare this battery pack with the one used in the mobile robot described in previous work [1],[2],[3] and [4]. In the last application the robot had three 12V lead acid batteries each with 6.5Ah. Two of those three batteries are connected serially. The pack's energy is:

$$24 \times 6500 + 12 \times 6500 = 234Wh \quad (4.6)$$

The new battery pack with his energy of 312 Wh gains 33% in energy.

The total weight of the three 'Lead Acid' batteries is almost $8kg$. The specific energy is around $30Wh/kg$. The new battery pack gains almost 80% !

The energy density of the Lead batteries;

$$\frac{234}{3 \times 0.15 \times 0.065 \times 0.095} = 84kWh/m^3 \quad (4.7)$$

When we compare (4.5) with (4.7) we see a factor 2.5 difference. This means two and an halve time more energy in the same volume! Actually we loose some space between the cells.

4.2.3 Autonomy

We can estimate the entire robot's autonomy, when we estimate the power consumption of each module. Assume the robot equipped with:

- PC, $100W$
- 10 ultrasonic sensors (6500 Polaroid)[13], $10 \times 5V \times 500mA = 25W$
The sensor has a peak current of $2000mA$, the continuous current is $100mA$, to estimate the power consumption of the sensors we assume a mean current of $500mA$.
- Electronic compass (Devantech)[14] $5V \times 15mA = 75mW$
- 10 infrared sensors (Sharp GP2D12)[15], $10 \times 5V \times 50mA = 2500mW$
- Pan/Tilt camera (Sony EVI-D31)[16], $11W$
- Motors, $100W$
Hence in this chapter the two motors are discussed in more detail. In this estimation we assume the power consumption of both motors $100W$.
- Electronics, $15W$

This estimation seems reasonable, it includes the loss in the motor amplifiers, and interface electronics.

More details on the used sensors can be found in the specific datasheets.

When we add all estimated powers together we have a total power consumption of $254W$. The autonomy of the robot equipped with the NiMH battery pack is then $312Wh/254W = 1.2h$ or $72min$.

4.2.4 Battery Charger

Charging self made battery packs is not obvious, especially not in this case. We need a charge terminal that is able to charge twenty cells in one time. A charge terminal with this capability is shown in Fig.4.7. This terminal is intended for charging NiCd and NiMH storage battery packs consisting of 1 to 20 cells. The nominal capacity of these storage battery types indicated in mAh is not important. This terminal can also be used for charging standard Lead Acid storage batteries, Lead Fleece and Lead Gel storage batteries if they consist of no more than 1 to 6 or 12 cells. The nominal capacity of these storage battery types has to be within $500mAh$ to $100Ah$. More details on the charge terminal can be found in [17]. The charging time to charge the NiMH battery pack is estimated between $6h-9h$.



Fig.4.7
Charge Terminal 3000 [17]

4.3 Mechanic Design

Let us focus now on the mechanics in the lower platform and work out the proposed concept. All parts of the lower platform are designed in ‘AutoDesk Inventor’ a computer aided design (CAD) program. The technical drawings are appended in appendix B. The designed parts are either developed by the VUB technicians, or they are bought in specialised stores because of their complexity.

The proposed concept leads to a symmetric design (Fig.4.8) which will increase the robot’s stability. We shall start with the steer and drive accommodation. In the synchro drive configuration the mechanism to drive and to steer a single wheel is repeated three times. Because these three mechanisms ensure the robot’s contact with the ground, we will call the mechanisms the legs of the robot. Between the three legs, there is some space to put the two motors necessary to drive the wheels and rotate all legs and the upper platform. The specific motor electronics can also be placed between the legs. The proposed battery pack has a symmetrical shape, and is fitted in between the legs of the robot too. This explains the configuration of the battery pack.

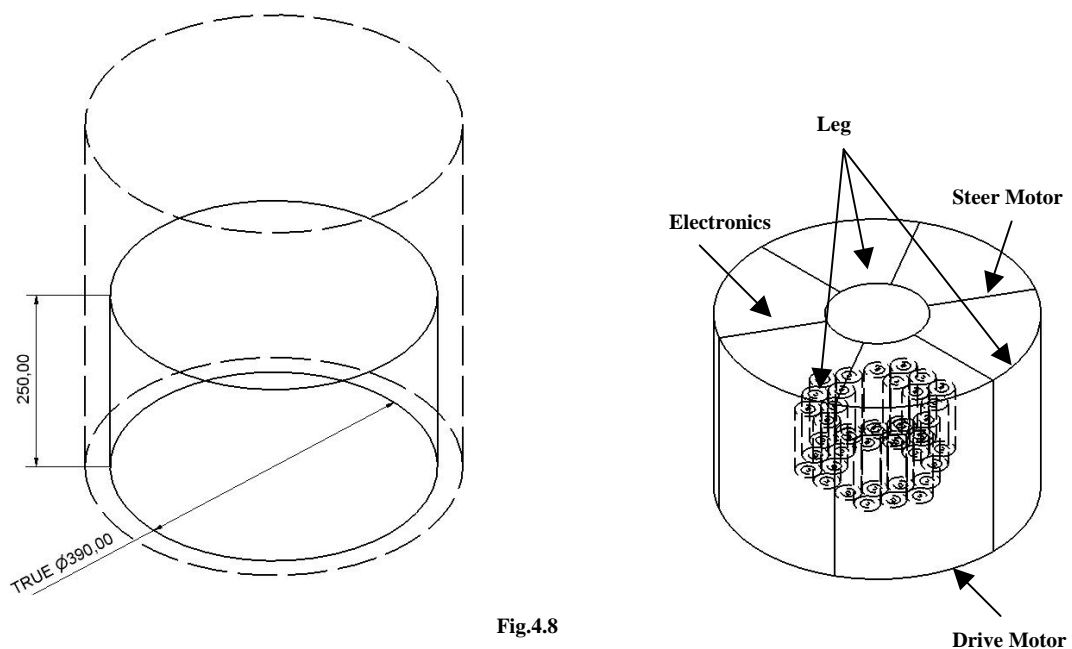

Fig.4.8

Black box analogy, symmetrical concept of the lower platform

4.3.1 Robot's Leg

4.3.1.1 *Driven Steered Standard Wheel*

The robot's legs are the most important assemblies of the mechanical platform and they have three major functions. First of all the ground contact must be ensured. The three legs together must be able to hold the entire weight of the robot. Secondly the leg must act as a steered standard wheel. And finally the wheel has to be driven to produce motion. Fig.4.9 shows the real leg, and a drawing of the leg made in 'AutoDesk Inventor.'

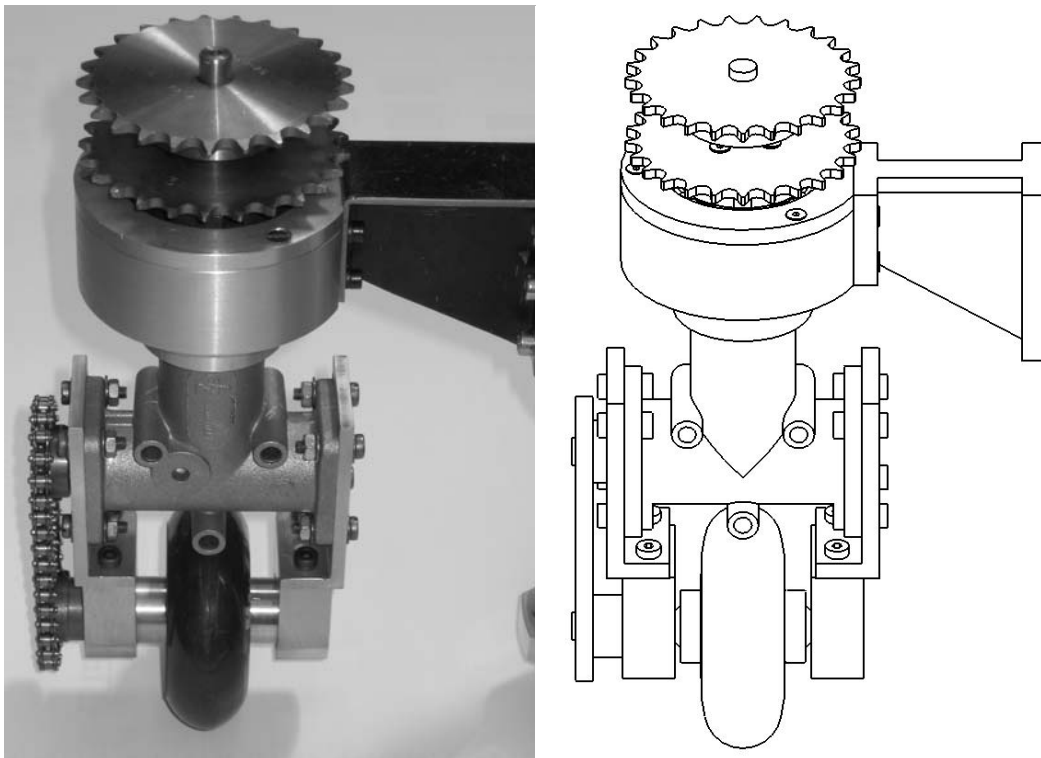

Fig.4.9
Robot's leg

The key part in the leg's assembly is the right-angle driver as given in Fig.4.10. In this device rotary power is transferred between two shafts at right-angles to each other with transmission ratio 1:1. This part is bought because of its complexity. Inside there are spiral bevel gears to reduce the backlash and to ensure a perfect gear engagement and silent operation. The incoming and outgoing shaft both have large bearings in deep races, and oil seal rings are fitted. The unit is filled with long-life grease. The housing is a single-piece aluminium alloy casting with three flanges as mounting points.

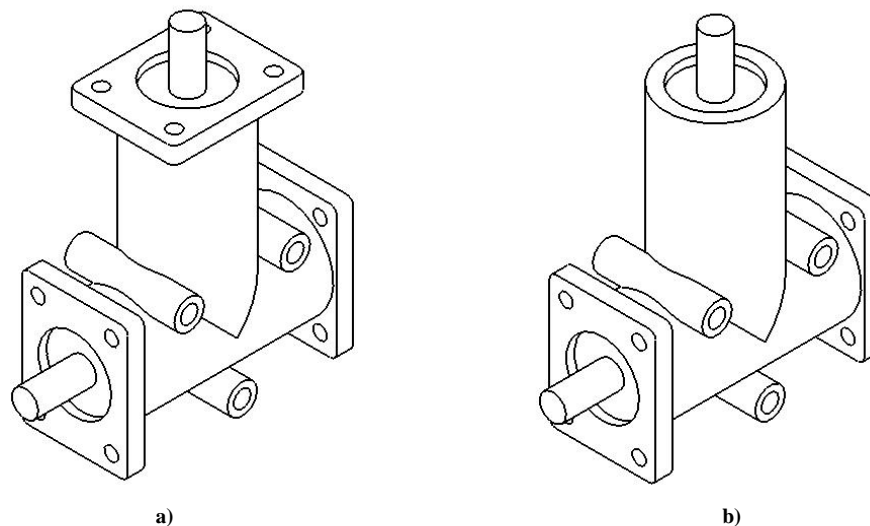

Fig.4.10

a) **Right-angle driver**

b) **Modified right-angle driver**

This unit allows us to transfer the rotary power of the drive motor to the wheel in the leg. The upper flange is removed for reasons that will be clear further in this section. On the two parallel flanges a fork is mounted which contains the wheel spindle (Fig4.11.a). Between the outgoing shaft (the lower one in Fig.4.10) and the wheel spindle the transmission occurs with a small chain with a ratio 1:1. To reduce inaccuracy and loss of exact wheel position a mechanism to tighten the chain is necessary. Therefore the fork must be able to move up and down. The holes to mount

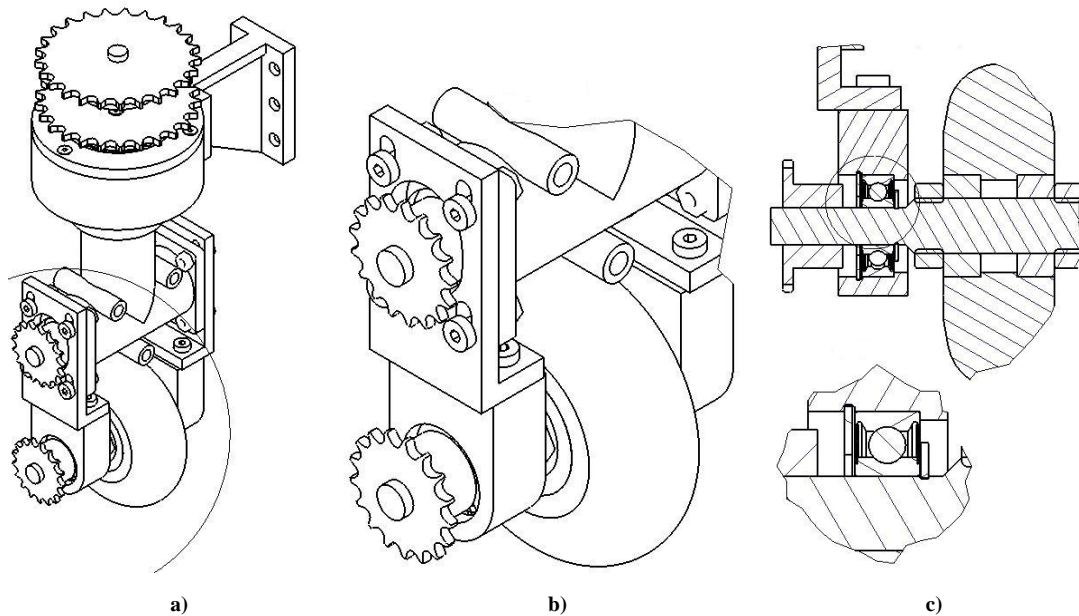

Fig.4.11

- a) Overview leg
- b) Detail view of the fork with transmission and mechanism to tighten the small chain
- c) Section view of the wheel spindle and detail view of the bearing housing

the fork to the right-angle driver are actually grooves to make this possible (Fig.4.11.b). When the chain is tightened according specifications, the bolts and nuts can be screwed down to fix the fork.

In Fig.4.11.c the wheel spindle is shown. Inline skate wheels are used. These wheels have always the same core, but can differ in size, shape, rebound, hardness and moreover they are low cost. In the first design the possibility to change a wheel was worked out. That way we were able to adapt the wheels on an easy way to the ground the robot was riding on. To reduce the construction time the wheel is mounted fixed on the spindle and preclude the possibility to change wheels easily. The figure indicates also the ball bearing that supports the axle, and guarantees a smooth rotation, and the way it is held in its bearing housing with a locking washer. The wheel spindle is also kept on its place by a smaller locking washer. That way the wheel axle and bearings can not move axially anymore.

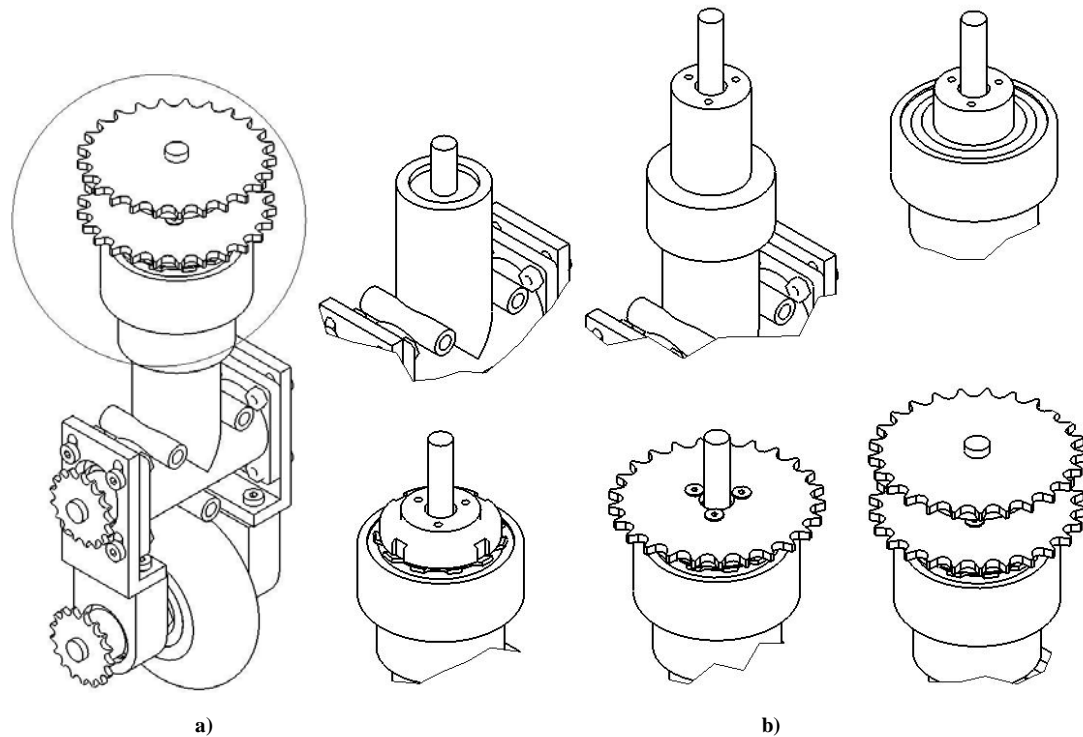

Fig.4.12

a) Overview leg

b) Detail view of the assembly of the steer and drive mechanism

Let us focus now on how to make the leg a steered standard wheel. Fig.4.12.b shows us the successive steps to achieve this. On the modified right-angle driver a part is mounted, we will refer to this part as *part X*. In this part *X* the incoming shaft of the driver is enlarged and enwrapped with a plain bearing to ensure smooth motion. Part *X* has a lock bolt which is not visual on the figure. When this bolt is loose, we can distort part *X* and the entire fork with the wheel in it. When we screw down the lock bolt the two parts are fixed to each other. This distortion is needed to align the three wheels as we shall see.

Over part *X* we place a rolling bearing. The top of part *X* is threaded. This way we can screw down the bearing with a locking washer and a locking nut. On top of part *X* we mount a chain wheel. Finally we mount a chain wheel with a hub on the enlarged incoming shaft.

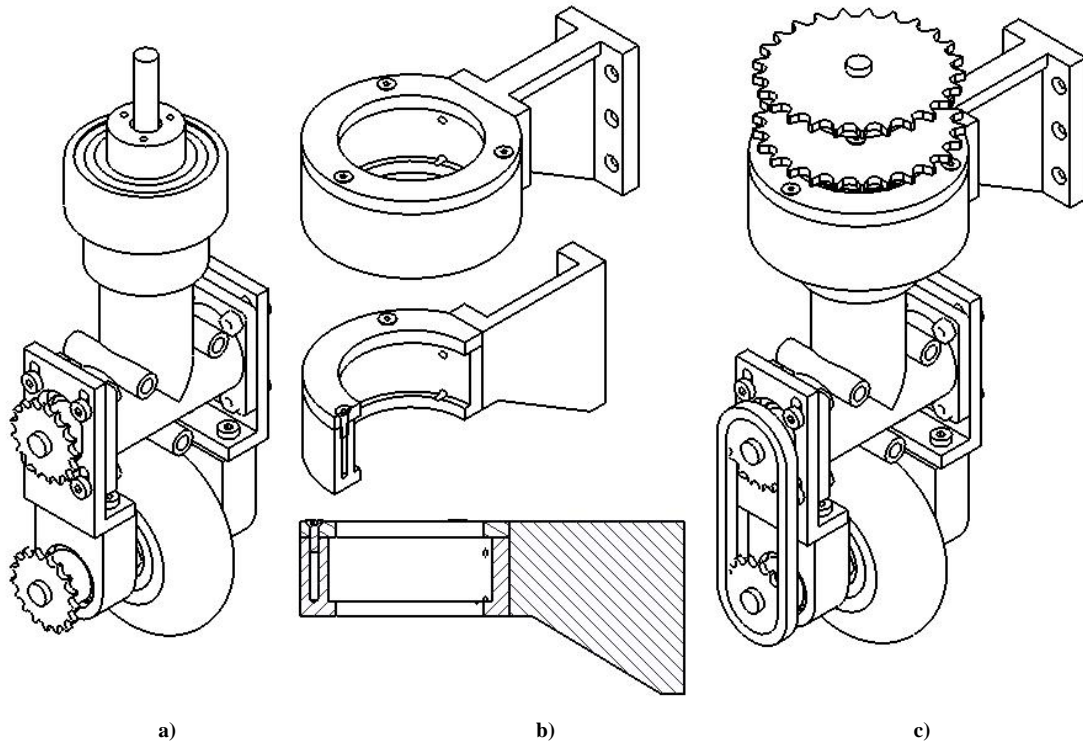

Fig.4.13

- a) Partial assembled leg
- b) Bearing housing leg
- c) Complete assembled leg

Now the partial assembly is placed in a bearing housing as in Fig.4.13.b. This bearing housing exists of two parts screwed together with the rolling bearing between them. The result is shown in Fig.4.13.c. This is a presentation of the entire assembled leg which acts like a driven steered standard wheel. Assuming the bearing house fixed; the wheel will rotate when we turn the upper chain wheel and the orientation of the wheel will change when we turn the lower chain wheel.

4.3.1.2 *Bearings*

Before moving on to the motor choices we take a closer look at the used bearings in the legs. The most important bearing in the leg is the bearing over part X. This bearing is actually a double row angular contact ball bearing. In fact the bearing corresponds in design to two single row angular contact ball bearings, but takes up less axial space. Normally we need to place there two single row angular contact ball bearings to support the axial forces due the weight of the robot. The axial force needs to be absorbed in both directions because we do not want to lose the wheels when we pick up the platform. This could happen when the leg weighs too heavy. When the bearing can not hold the weight axially, then the bearing breaks and drops the wheel. To solve this problem we have to use two similar bearings. When using two single row angular contact bearings we have to place them back-to-back or face-to-face to absorb the axial forces in both directions. We refer to [18] for more information. In stead of these two bearings we use the double row angular contact ball bearing.

The bearing's capabilities are actually exaggerated. But we were forced to take this bearing because of the dimensions of the inner diameter. This bearing is equipped with seals to keep the grease necessary for smooth rotary motion inside.

The bearing life is also exaggeratedly high, and can be calculated with the formulas in [19]. We can assume the bearing working statically.

The smaller bearings used in the legs are just to support the wheel axle, and are bearings similar to the bearings used in inline skate wheels. They need no further comment.

All other bearings used in the whole mechanical platform are plain bearings. They support or guide other parts and that way ensure smooth rotary motion.

4.3.2 Motors

4.3.2.1 *Drive Motor*

As we already know, there are two motors in the mechanical platform. First we examine the drive motor. This motor must be able to drive the three wheels together and produce motion in that way. To determine the needed power and torque of the motor, we use a simple vehicle model as depicted in Fig.4.14.

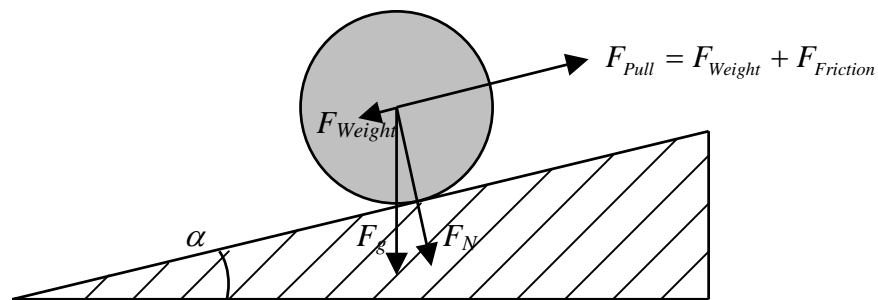

Fig.4.14
Simple vehicle model

The vehicle with mass m is pulled onto a slope with an angle α with the horizontal. The force needed to do this is called F_{pull} :

$$F_{Pull} = F_{Weight} + F_{Friction} \quad (4.8)$$

$$F_{Pull} = mg \sin \alpha + \mu mg \cos \alpha \quad (4.9)$$

$$F_{Pull} = mg(\sin \alpha + \mu \cos \alpha) \quad (4.10)$$

Appraisal rule of thumb values for motor selection are:

$$\alpha = 15^\circ \text{ and } \mu = 0.05 \quad (4.11)$$

μ is an estimated friction coefficient of a rolling wheel.

The proposed mean speed in the ‘Melexis Safety Trophy’ is $2km/h$ or $0.56m/s$. To be sure the robot drives fast enough we assume a maximum speed of four times the proposed mean speed:

$$v_{\max} = 8km/h = 2.2m/s \quad (4.12)$$

The power needed to drive the robot at a certain speed:

$$P = F_{pull} \cdot v \quad (4.13)$$

$$P_{\max} = F_{pull} \cdot v_{\max} \quad (4.14)$$

When we assume the robot’s mass $20kg$ we need a motor power of:

$$P_{\max} = mg(\sin \alpha + \mu \cos \alpha) \cdot v_{\max} = 60W \quad (4.15)$$

This value seems acceptable. Knowing that there are electrical steps with a motor of $100W$, which are able to drive at a similar speed with an adult person on it. To be sure about the calculated power an experiment was done to compare the experimental motor power with the calculated motor power.

In this experiment a cart with a load of $20kg$ on similar wheels was pulled forward with a drawing spring. The tractive pulling power to get motion was measured with the spring. We noticed that the pulling force reduces once the cart is moving. We took the highest measured value and we introduced a safety factor of four. The experimental pulling force was then:

$$F_{PullExp} = C \cdot F_{Spring} = 4 \cdot 5N = 20N \quad (4.16)$$

When we put these value in (4.15) we get:

$$P_{\max} = F_{PullExp} \cdot v_{\max} = 20N \cdot 2.2m/s = 44W \quad (4.17)$$

The new estimated motor power seems also reasonable.

The motor torque is given by:

$$P_{\max} = \omega \cdot C_{\max} \quad (4.18)$$

$$P_{\max} = 2\pi N_{Motor} \cdot C_{\max} \quad (4.19)$$

with N_{Motor} the number of revolutions per second.

As we shall see the transmission ratio between the motor and the wheels is 1:1. We can now calculate the N_{Motor} as follows:

$$v_{\max} = 8\text{km} / \text{h} = 2.2\text{m} / \text{s} = N_{Wheel} 2\pi r \quad (4.21)$$

$$N_{Wheel} = N_{Motor} = \frac{v_{\max}}{2\pi r} = \frac{2.2}{2\pi \cdot 0.034} \approx 10\text{rps} \quad (4.22)$$

With (4.20) we can calculate the motor torque:

$$C_{\max} = \frac{P_{\max}}{2\pi N_{Motor}} = \frac{44}{2\pi \cdot 10} = 0.7\text{Nm} \quad (4.23)$$

The quest to a suitable motor can start now. We decide to try one of the motors used in the robot described in [1],[2],[3],[4]. This motor fulfils the requirements.

Some motor specifications are:

- Assigned power rating, 70 W
- Nominal voltage, 18 V DC
- No load speed, 6610 rpm

To reduce the motor speed, and to increase the torque a gearbox is mounted on the motor. The ratio of this planetary gearhead is 18:1. On the other side of the motor an optical encoder is mounted. More details about the motor, gearhead and encoder can be found in [20]. Fig.4.15 shows the used motor with gearhead and encoder.



Fig.4.15

Maxon motor (RE36) with gearhead GP32A(18:1) and encoder (HEDL5540)[20]

4.3.2.2 *Steer Motor*

The second, and last motor to choose is the steer motor. Two types of motors can be considered for the steering task; stepper motors or servo motors. Let us compare these two motor types.

Servo motors are standard DC or brushless motors with an encoder feedback loop. As used in the drive application. The controller reads the position of the motor and controls the power applied to the motor. Servo motors are faster moving point to point and are better at accelerating very heavy loads than stepper motors. Servo motors are more expensive than steppers, perhaps double the price, or more. They are generally just as accurate, if maintained in a proper state of tune, however they rely on encoders to provide positioning information back to the computer. Thus the complexity of the system is at least doubled, with no accuracy advantage, greater initial cost, and more maintenance issues.

Stepper motors are permanent magnetic motors that 'step' one increment each time the controller gives its control electronics one pulse. This is done with the assumption that the shaft rotates the specified number of steps. No realtime feedback is provided to assure the motor maintains pace with the desired motion sequence. Stepper motors are relatively inexpensive, and provide the same or greater accuracy as servo motors. Sufficiently powerful stepper motors for a given application do not lose steps. Stepper motors are no more likely to lose steps than a servo encoder is to pass bad information back to the controller.

If for some reason a stepper motor does encounter an obstacle it can not overcome, such as blocked wheels, it will simply skip steps, without harming anything. If a servo motor encounters the same obstacle, it fight itself until it breaks a gear tooth or burns up.

The 'closed loop' rhetoric sounds convincing to the uninitiated, but provides no benefit over a simpler and cheaper reliable stepper system. That is why we decide to

take a stepper motor. In Fig.4.16 we see some specifications of the chosen stepper motor. The stepper has a step angle of 0.9° .

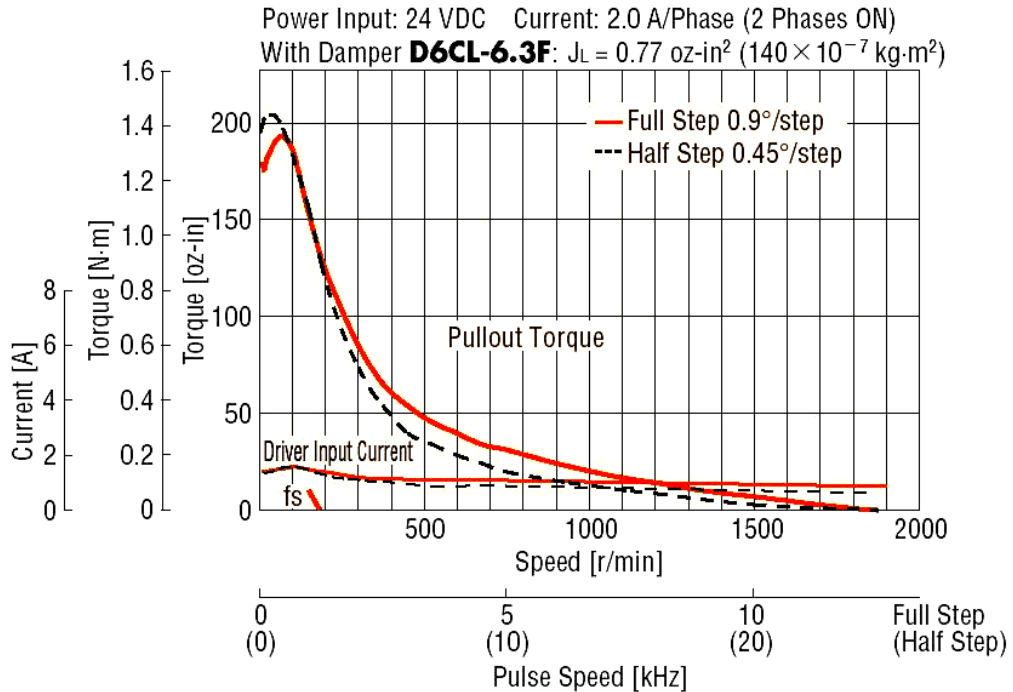

Fig.4.16
Characteristics stepper motor [21]

It is not easy to calculate the requirements of a stepper motor, especially not when the mechanism, in which the motor is used, is not determined yet. However these formulas [21] can be used to compare the motor specifications with the requirements:

- Checking the running duty cycle;

A stepper motor is not intended to be run continuously with rated current. Lower than 50% running duty cycle is recommended.

$$\text{Running Duty Cycle} = \frac{\text{Running Time}}{\text{Running Time} + \text{Stopping Time}} \times 100$$

- Checking the Inertia Ratio;

Large inertia ratios cause large overshooting and overshooting during starting and stopping, which can affect start-up times and settling times. Depending on the on the conditions, operation may be impossible. With the following equation we can check that the values found are below the reference inertia ratios given by the constructor.

$$\text{Inertia Ratio} = \frac{\text{Total Inertia Of The Machine [kgm}^2\text{]}}{\text{Rotor Inertia Of The Motor [kgm}^2\text{]}} \leq 10$$

When this value is exceeded, we have to take a geared motor. Using a geared motor can increase the drivable inertia load.

$$\text{Inertia Ratio} = \frac{\text{Total Inertia Of The Machine [kgm}^2\text{]}}{\text{Rotor Inertia Of The Motor [kgm}^2\text{]} \times (\text{Gear Ratio})^2} \leq 10$$

- Checking the acceleration and deceleration rate;

Most controllers, when set for acceleration or deceleration, adjust the pulse speed in steps. For that reason, operation may sometimes not be possible even though it can be calculated. Calculate the acceleration/deceleration rate from the following equation and check that the value is at or above the acceleration/deceleration rate given by the constructor.

$$\text{Accel / Decel Rate} = \frac{\text{Accel / Decel Period [ms]}}{\text{Operating Pulse Speed [Hz]} - \text{Starting Pulse Speed [Hz]}}$$

$$= \frac{t_1}{f_2 - f_1} \leq 20$$

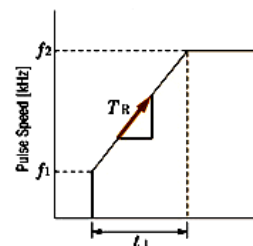

- Checking if the required torque falls within the pull-out torque of the speed-torque characteristics. (Fig.4.16)

The first and the third condition present no problem in our application. The other two conditions are hard to check. That is the reason why we opt for a stepper that is probably too strong for this application. However this choice adds some modularity in the whole concept because we are able to equip the upper platform with tools for different tasks, and the stepper will probably still be able to turn the platform quite fast. All this at a cost that is rather limited. Fig.4.17 shows the motor itself.

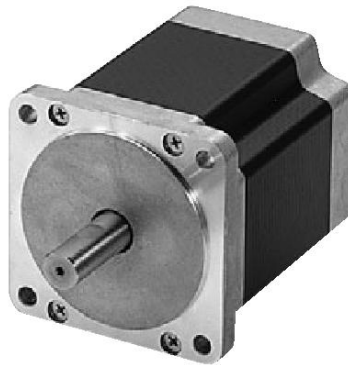

Fig.4.17

Vexta stepper motor (CSK268MBT)[21]

4.3.3 Frame and Transmission

4.3.3.1 Frame

In Fig.4.18 we see the blackbox analogy. The battery pack, the legs, and the motors are already worked out. In this section we take a look at the frame of the mechanical platform. This frame is the structure that holds all parts together.

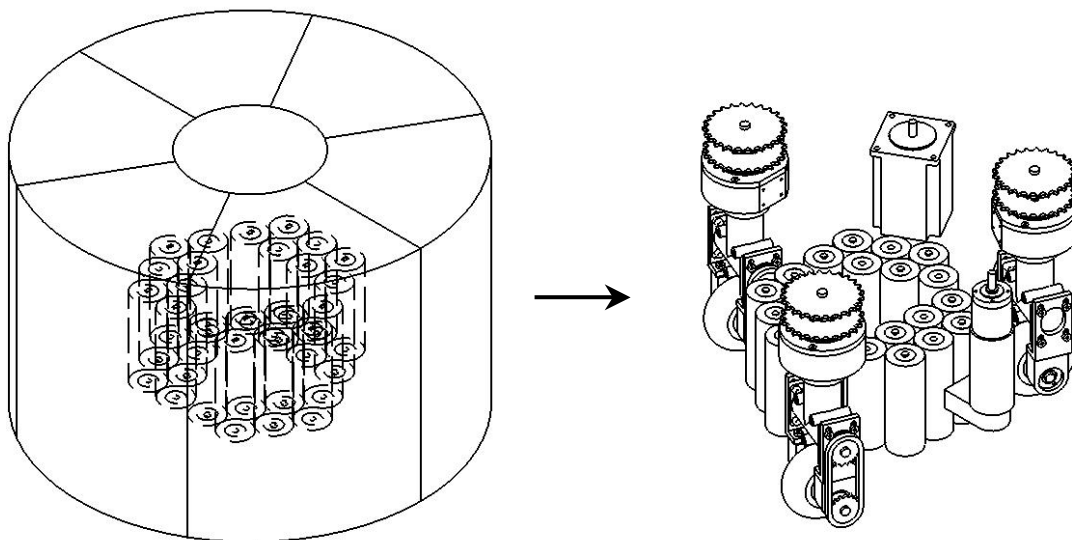

Fig.4.18
Blackbox analogy

The main part in the frame is shown in Fig.4.19. Let us refer to this part as *part Y* next in this section. Part Y is the biggest, and heaviest part but is quite easy to construct. Most of the manufacture processes can be done with the lathe. Despite its weight the stability stays assured, by placing this part in the centre of the mechanical platform. This part is the base part of the mechanical platform and all other parts or modules are attached on it. On the bottom of part Y a plate which hold the batteries and electronics is screwed down and around part Y the three legs and two motors are fixed.

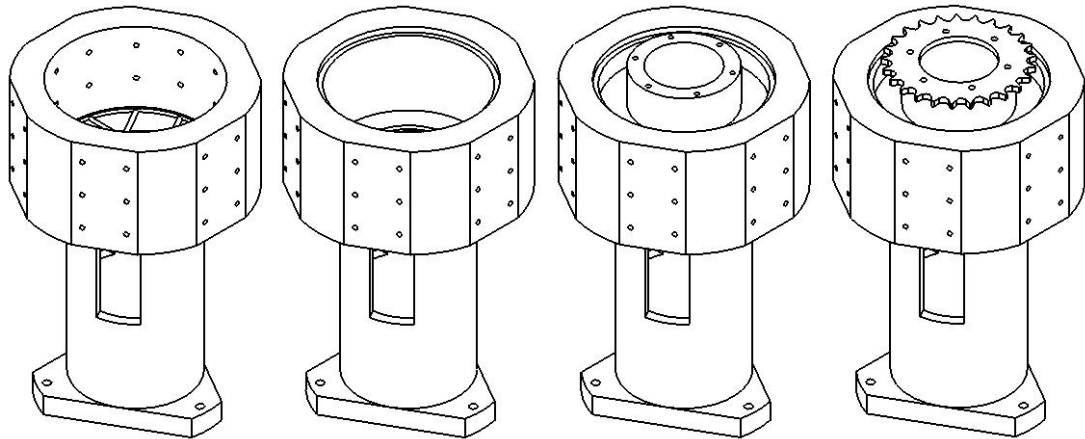

Fig.4.19
Main socle and its inner parts

The wires specific to the motors and battery pack are lead away through the three holes in the middle of the socle. In part Y we place first two plain bearings, one on the bottom of the inner side, the other around the inner mantle (Fig.4.19). Next we place a second part, *part Z*, inside the enveloped part Y. Finally we screw down a plated chain wheel on top of part Z. Part Z can now freely rotate in part Y. It is on part Z that the upper platform will be attached. We get (Fig.4.20):

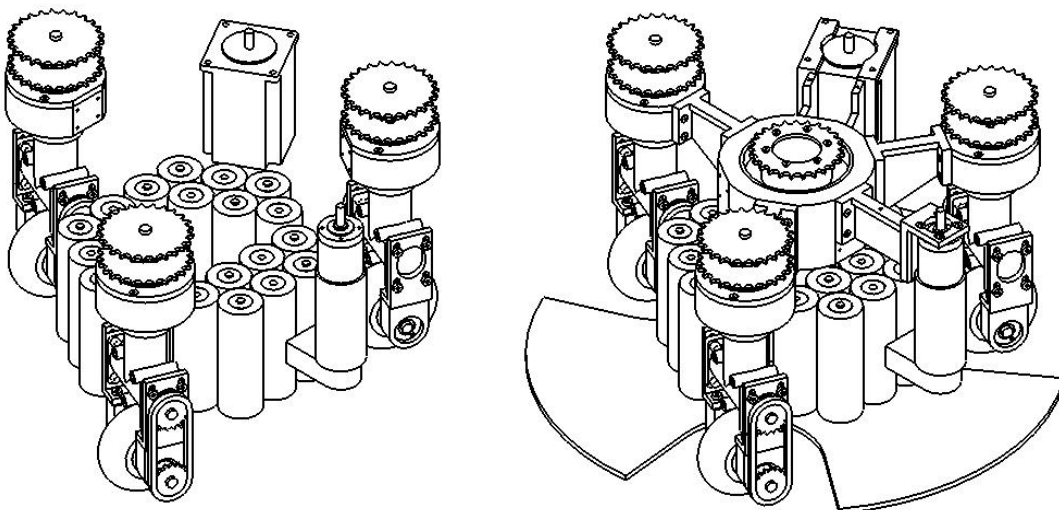

Fig.4.20
Supporting frame

4.3.3.2 Transmission

There still rests us the transmission mechanism. We decide to transmit rotary motion by chains. Other possibilities are belts or gears. Gears are heavy and take a lot of space. The main disadvantage of belts is its slippage. It is very difficult to ensure the parallel alignment, and to calculate the robot's position when there is slippage. To solve the problem of slippage we can opt for chains or toothed belts. Toothed Belts and the specific pulleys are a good alternative way to transmit motion power. The main disadvantage of a chain transmission is its backlash. This backlash is rather limited by the small pitch (8mm) of the chains. Knowing that the chains backlash is only two percent of the chain's pitch, the backlash is acceptable in this application. The chain transmission is also a bit smaller than a similar toothed belt transmission. In an application where space is rather limited these facts can be convincing.

There are two large chains as shown in Fig.4.21. The first one, between the drive motor and the three upper chain wheels of the legs, will be referred to as the upper chain. The second one, between the steer motor and the lower chain wheels of the legs, will be referred to as the lower chain. All transmission ratios are chosen 1:1.

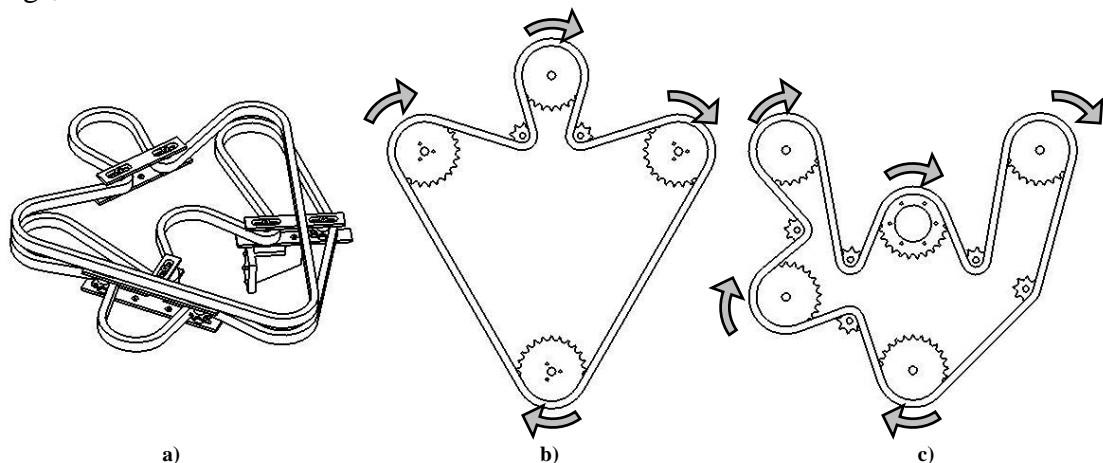

Fig.4.21

- a) Transmission mechanism
- b) Upper chain
- c) Lower chain

The upper chain mechanism is quite easy. There is only one mechanism needed to tighten the chain. The two small chain wheels shown in Fig.4.21 can slide to obtain this. When the chain is tightened according specifications the small guiding chain wheels are screwed down and lose their possibility to slide.

The lower chain needs such a slide system between every chain wheel of the leg, and the chain wheel of the upper platform, to ensure the precise alignment. Remember all wheels have to be aligned perfectly parallel to obtain straight line motion. This way and the possibility to distort the wheel fork makes it able to align the wheels and the upper platform. The second reason to add these slide mechanisms are to tighten the chain.

When we put all parts so far together we have the finished mechanical platform without electronics nor software (Fig.4.22). Notice, to limit the robot's weight, all parts are made of aluminium, except the connection parts to hold the legs motors and chain assembly. These parts are in steel so they could be welded.

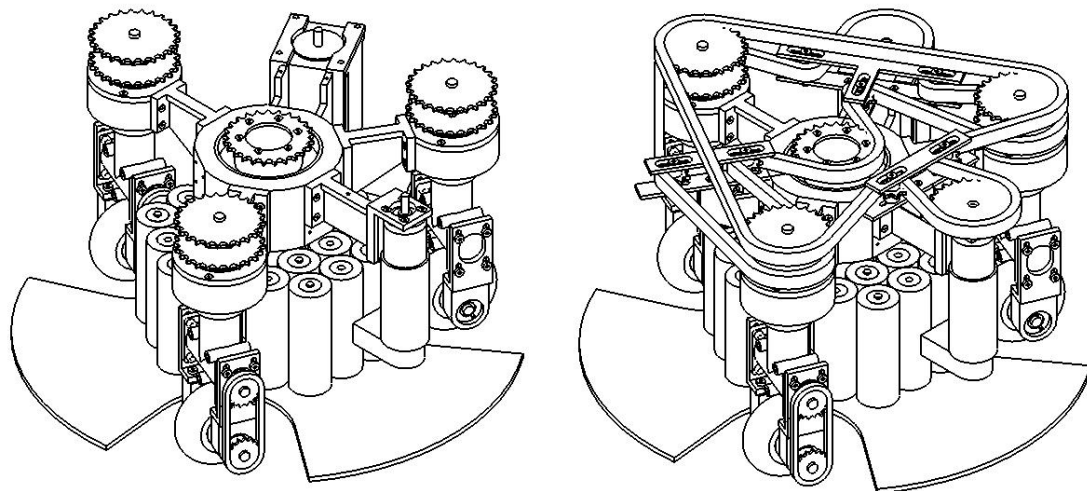

Fig.4.22

a) Mechanical platform and implementation transmission mechanism



b) Real mechanical platform

4.4 Electronic Design

Generally the control loop of the system is presented in Fig.4.23. We distinguish two different loops. The left loop is closed by an operator. This means, it is the operator's task to react on the motion behaviour of the robot. When he/she decides to change the motors' set values the response will be visual in a different motion behaviour. The right loop, is the loop of an autonomous system. There is no operator anymore to decide the motors' set values. In stead of the operators eyes, the robot itself must see the motion behaviour and the possible consequences. This can be done by sensors. Next it has to decide whether the motors' set values need to be changed or not. Notice the modules in the dotted square are the same in both control loops. When these modules are worked out we can use the mechanical platform for different applications.

The mechanisms in the mechanic module are already cleared out in the previous section. There rests us to explain the steer and drive electronics and the software modules. In this section we investigate the needed electronics, and the next section will handle the software.

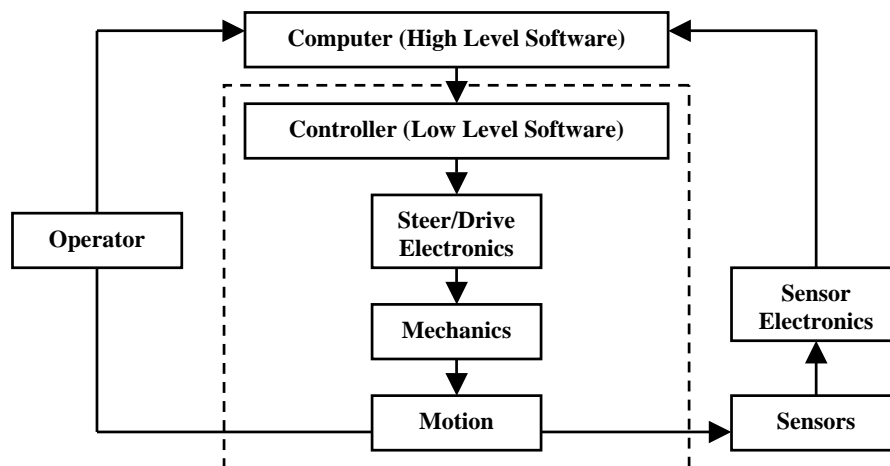

Fig.4.23

Control loops:
left loop with operator
right loop autonomous control with sensors

The mechanical platform contains only the electronics needed to drive and steer the chassis. That way we limit also the wires and connectors through the socle, and we limit the risks of twisted wires. The electronics needed to perform a well defined task, such as sensors, the main computer and power supply distributing, are worked out on the upper platform. We shall not discuss this modules in this thesis.

The mechanical platform contains three basic electronic modules as shown in Fig.4.24. Let us take a closer look at each of these modules.

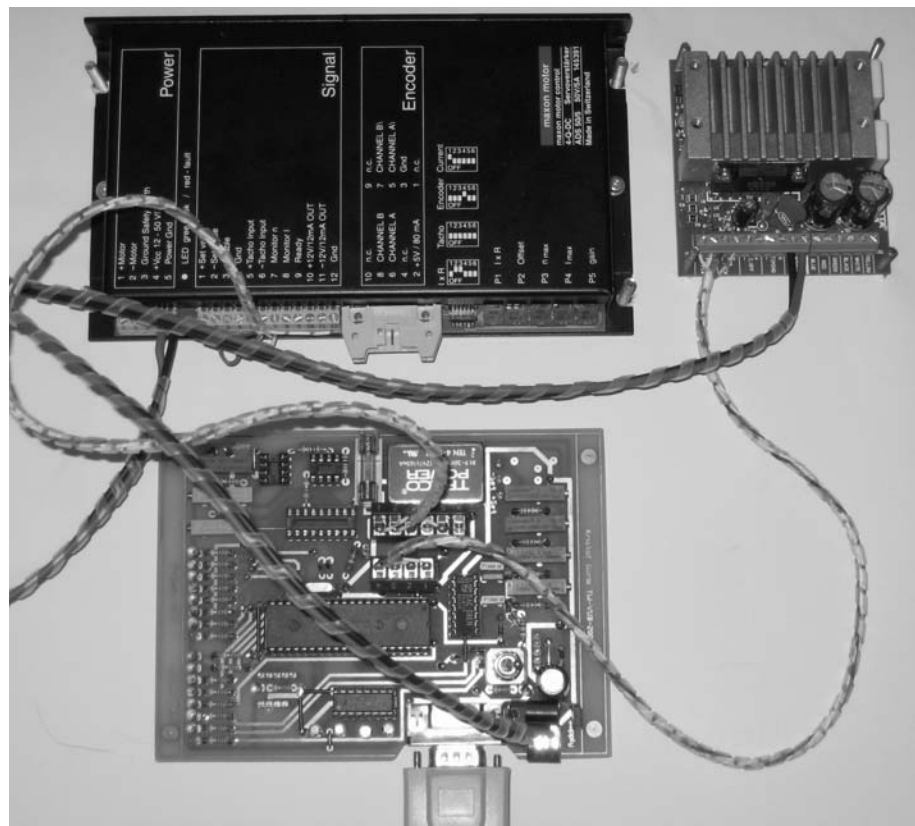

Fig.4.24

Three electronic modules used in the mechanical platform

4.4.1 Drive Motor Electronics

The first module we discuss is the drive motor amplifier. The ADS 50/5, shown in Fig.4.25.a, is a servo amplifier for driving permanent magnet DC motors. Four modes can be selected by DIP switches on the board:

- Speed control using tacho signals
- Speed control using encoder signals
- IxR compensated speed control
- Torque or current control

We decide to select the speed control using encoder signals, because the used motor is equipped with an encoder. The amplifier has a wide input supply range. More details on this device can be found in [22].

Of importance in this part of the design are the required inputs to drive the motor at a certain speed, and the outputted information.

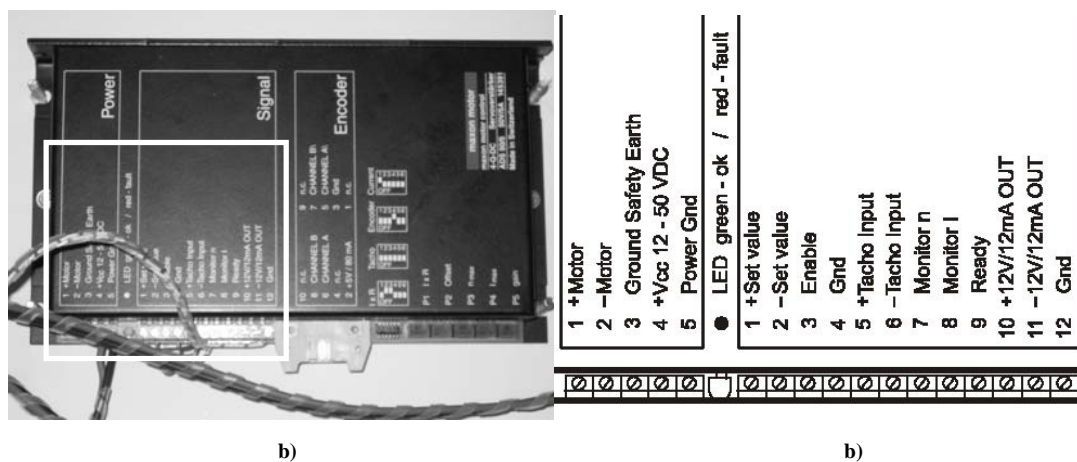

Fig.4.25

- a) Servo amplifier (ADS 50/5)[22]
b) Inputs and outputs

4.4.1.1 *Inputs*

Connectors one to five, shown in Fig.4.25.b at the left, are the power supply of the motor, and the module itself.

The set value input (connectors one and two in Fig.4.25.b at the right) is wired as a differential amplifier. The input voltage range is between $-10V$ and $+10V$. There are two possibilities[22]:

- Positive set value;
When the ‘+ Set Value’ $>$ ‘- Set Value’ we apply negative motor voltage or current and the motor shaft will turn counter clock wise (CCW).
- Negative set value;
When the ‘- Set Value’ $>$ ‘+ Set Value’ we apply positive motor voltage or current and the motor shaft will turn clock wise (CW).

When a voltage (between $+4V$ and $+50V$) is given at ‘Enable’, connector three in the figure, the servo amplifier will switch the motor voltage to the winding connections. If the ‘Enable’ input is not switched on or is connected to the ‘Gnd’, the power stage will be highly resistant and will be disabled.

4.4.1.2 *Output*

The speed monitor ‘Monitor n’, connector seven in the figure, is primarily intended for the qualitative estimation of the dynamics. The absolute speed is determined by the properties of the speed sensors and by the setting of the n_{max} potentiometer. The output voltage of the speed monitor is proportional to the number of revolutions and will be $+10V$ or $-10V$, depending of the rotation direction, when the maximum number of revolutions set by the n_{max} potentiometer has been reached.

4.4.2 Steer Motor Electronics

The second module is the steer motor amplifier. The CSK high-torque 2-phase stepping motor unit (Fig.4.26.a) has two working modes[22]:

- One-pulse input mode;
When the 'PULSE' input is turned from 'ON' to 'OFF' while 'DIR' input is set 'ON', the motor will rotate one step CW. When the 'PULSE' input is turned from 'ON' to 'OFF' while 'DIR' input is set 'OFF', the motor will rotate one step CCW.
- Two-pulse input mode;
When the 'CW' input is turned from 'ON' to 'OFF' the motor will rotate one step CW. When the 'CCW' input is turned from 'ON' to 'OFF' the motor will rotate one step CCW.

We decide to take the one-pulse operating mode.

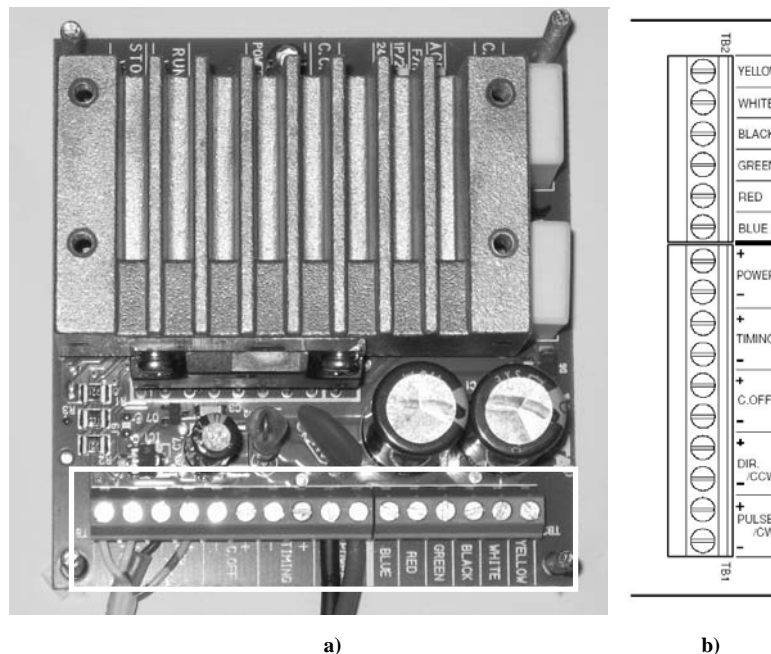

Fig.4.26
a) Stepper amplifier (CSK 2-Phase)[22]
b) Inputs and outputs

4.4.2.1 Inputs

The six connectors on top of Fig.4.26.b are the stepper motor winding connectors. Below them there are the power supply connectors. The supply is 24V or 36V with a deviation of ten percent. We use 24V to supply the device.

The connectors 'DIR./CCW' are used in one-pulse mode to determine the motors rotation sense. And finally the 'PULSE/CW' connector is used to determine the steppers stepping frequency. An input is set 'ON' when there is applied a voltage of 5V. The motor behaviour is shown in Fig.4.27.

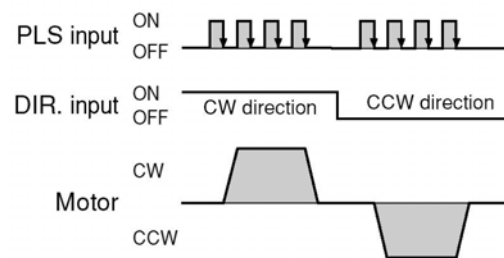

Fig.4.27

One-pulse stepper motor operation[22]

4.4.2.2 Outputs

The 'TIMING' signal indicates that the excitation of the motor is in the initial state. The signal is outputted once each time the excitation sequence returns to the initial state in synchronization with the input pulses. We do not use this output.

4.4.3 Interface Electronics

The third electronic module (Fig.4.28) is the interface between the computer and the two motor amplifiers. In fact it has two very important task to fulfil. First of all it communicates with the higher level systems, let us call this the computer. The second task is to pass on the required amplifier input values. To obtain this successfully, the PCB is equipped with a microcontroller. We shall refer to this microcontroller as the low level control system. So when we speak of high level control and high level software we mean everything that concerns the computer. When we mention low level control and low level software, we deal with the microcontroller. Let us take a closer look at the PCB.

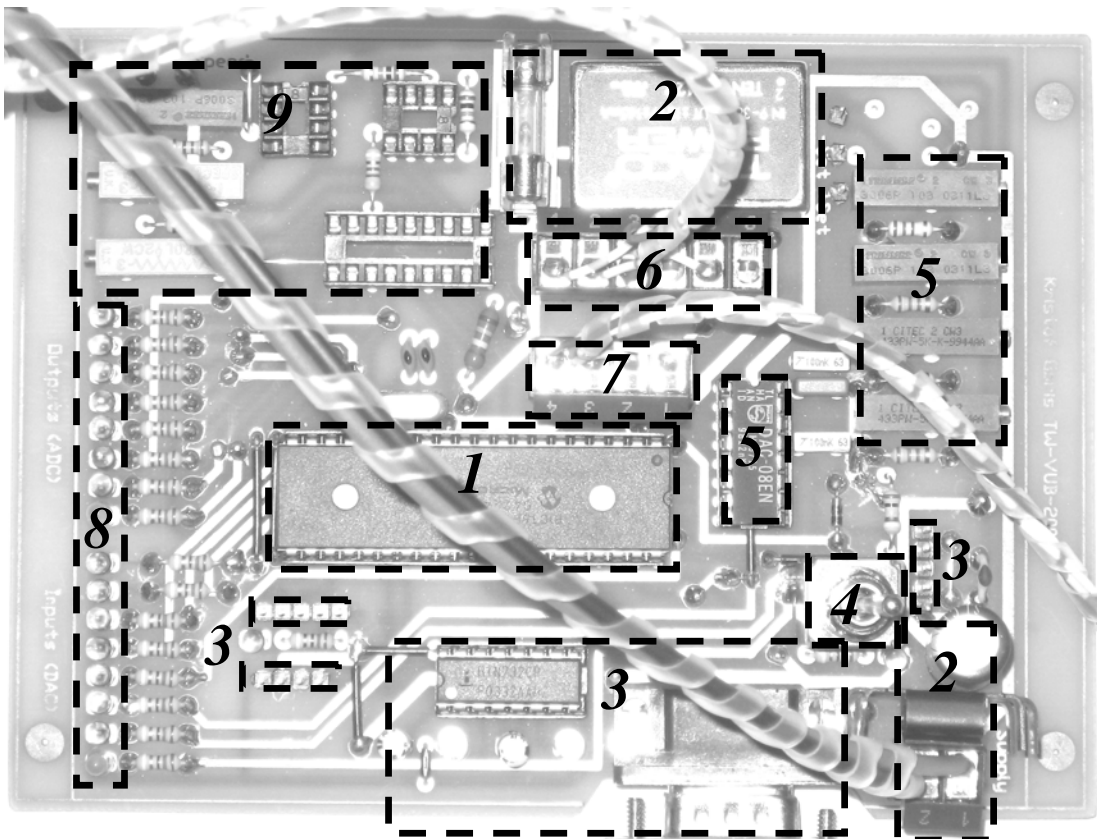

Fig.4.28

Interface electronics

4.4.3.1 *Microcontroller*

The used microcontroller is a *PIC16F877A*. For all details about this PIC we refer to the datasheets [23]. Our interests goes to the input and output possibilities, the clock which is used , the memory, the possibility to save a program in its memory and the instructions needed to program the controller. Some specifications of used PIC are:

- Operating Frequency: DC-20MHz
We use a crystal of 8MHz, this will be important in the software design.
- Flash Program Memory: 8K
- Data Memory (bytes): 368
- EEPROM Data Memory (bytes): 256
- Interrupts: 15
- Input/Output Ports: PortA, PortB, PortC, PortD, PortE
All these ports are used, however not entirely.
- Instruction Set: 35 instructions

This microcontroller is depicted in the dotted rectangle with number 1 in Fig.4.28.

4.4.3.2 *Voltage Regulation*

The incoming voltage of +24V is protected against inverse polarity, and is guide to the DC-DC converter. A fuse must protect the entire board for short circuits. The DC-DC converter converts the +24V into -12V and +12V.[24] These values are needed for other components on the PCB. Further the +12V is converted to +5V and a capacitor is used to removes the ripples. With the +5V we can supply the PIC and some other components. All these voltage regulate and convert components are shown in the dotted rectangles with number 2 in Fig.4.28.

4.4.3.3 *Communication and Programming*

In the dotted rectangles with number 3 in Fig.4.28, the communication components are shown. The MAX232 chip [25] and PIC are used to communicate. There are possibilities to communicate by serial connector (Serial COM) and I²C bus. To load a program we use the ‘In-Circuit Serial Programming pins’[23]. Switch ‘number 4’, has to point away from the programming pins to be able to load the controller with a program. After loading the switch has to be switched to put the PCB in operation mode.

4.4.3.4 *Digital to Analogue Converter*

In order to get the desired ‘Set Value’ used in the servo amplifier, we use a DAC to convert a byte into a voltage between $-10V$ and $+10V$. The circuit is worked out in the datasheets [24]. In Fig.4.28 number 5 corresponds with this circuit. The potentiometers are used to tune the out coming voltage.

4.4.3.5 *Analogue to Digital Converter*

The same principle is used to read the speed of the drive motor. The in coming voltage of ‘Monitor n’ is converted by a ADC to a byte. This circuit [25] is shown in the figure by number 9.

The two bytes concerning the motor speed, and motor ‘set value’ are also made visual by the LEDs (number 8).

The required data signals are available at connectors. Connector ‘number 6’ contains the required servo amplifier signals, connector ‘number 7’ the stepper amplifier signals.

4.5 Software Design

As mentioned in previous section we make a difference between the high level software and the low level software. The low level software is more or less limited by the limited instruction set to program the assembler code in the microcontroller. Therefore we design a high level software module as well as a low level software module. Fig.4.29 shows their relation.

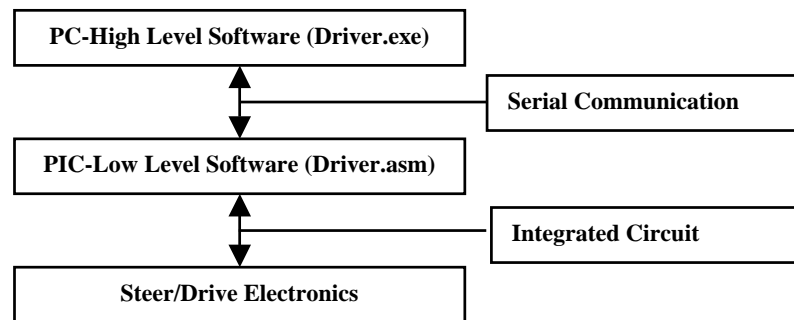

Fig.4.29
Relationship high and low level software

Before we work out each software module, we explain what we require of the software. We want to use the software as a interface between an operator and the electronics. More specific we need a control panel, or an operating system which make it possible to control the motion of the chassis. That is the high level software. Next the computer needs to communicate with the PIC, and the PIC have to translate it into usable bytes or signals and send it to the electronics. That is the low level software.

The control panel made in 'Visual Basic' is shown in Fig.4.30. It contains two sliders; the vertical slider determines a set value for the drive motor. When moving the slider to the top, the chassis will drive faster and faster. When the slider is moved to the bottom, the chassis will drive faster and faster in reverse direction. The second

slider determines a set value for the steer motor. When the slider is moved to the left, the wheels' orientation will change and the more the slider is moved to the left the faster the wheels are turning. When we move the slider to the right the same will happen but in opposite direction. The 'Reset' buttons will reset the specific slider and the corresponding motion will disappear. When the 'STOP' button is pressed the chassis will stop immediately. The 'End' button ends the application. The number shown in the white boxes are the same numbers used in the high and low level programs. The frequency of the stepper is visual even as the period to turn the wheels a entire turn.

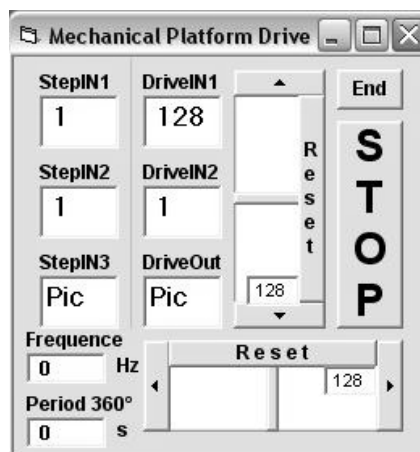
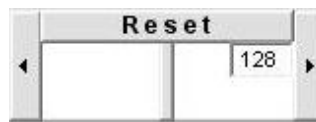

Fig.4.30

Control panel: Driver.exe

The program behind this control panel, just sends (by way of serial COM) four bytes to the PIC microcontroller, and receives one byte which is send to the screen. Also the bytes used in the assembler code are made visual. When the PIC receives something the loop where it was working in becomes interrupted. In the interrupt the received bytes are passed on and putted away in memory registers. The first and the last bytes are respectively '11111111' and '00000000' and are used for synchronisation. The two bytes between them are set values derived from the two slider values. The value of the vertical slider (DriveIN1) is passed on without more

and goes from 1 to 255. The value of the horizontal slider is modified in the high level program before it is sended to the PIC. The reason therefore, we want a symmetric behaviour of the steer motor when we slide to the left or to the right. The slider values are between '00000010' and '11111110'. The corresponding decimal numbers are respectively 2 and 254. The values after modification (StepIN1) are shown in Fig.4.31.



| | |
|----------------------------------|---|
| Slider value (decimal): | $2 - \dots - 127 - 128 - 129 - \dots - 254$ |
| Modified value (decimal): | $2 - \dots - 127 - 1 - (127+128) - \dots - (2+128)$ |

Fig.4.31

Values horizontal slider used in Driver.exe

For clearness' sake following flow chart (Fig.4.32). The Dark grey box deals with the high level program. The light grey boxes are at the low level, and the with boxes are the out coming data signals. In the dotted rectangle the interrupt is shown. The new values are copied and used when the loop in the main program (right side of the figure) is reseted.

When the four bytes arrive in the PIC an interrupt will called on as mentioned. The two data inputs of importance are copied in StepIN1 and DriveIN1. StepIN1 is copied in StepIN2. Bit8 is checked and determines the rotating sense of the stepper. Next the bits of DriveIN1 are switched, in other words bit1 becomes bit8, bit2 becomes bit7, and so on. The new byte is called DriveIN2, and is put on portB of the PIC. This port is connected with the DAC. All these operations are done In the interrupt. The DAC converts DriveIN2 into a voltage between $-10V$ and $+10V$.

Let us take a look at the main program now.

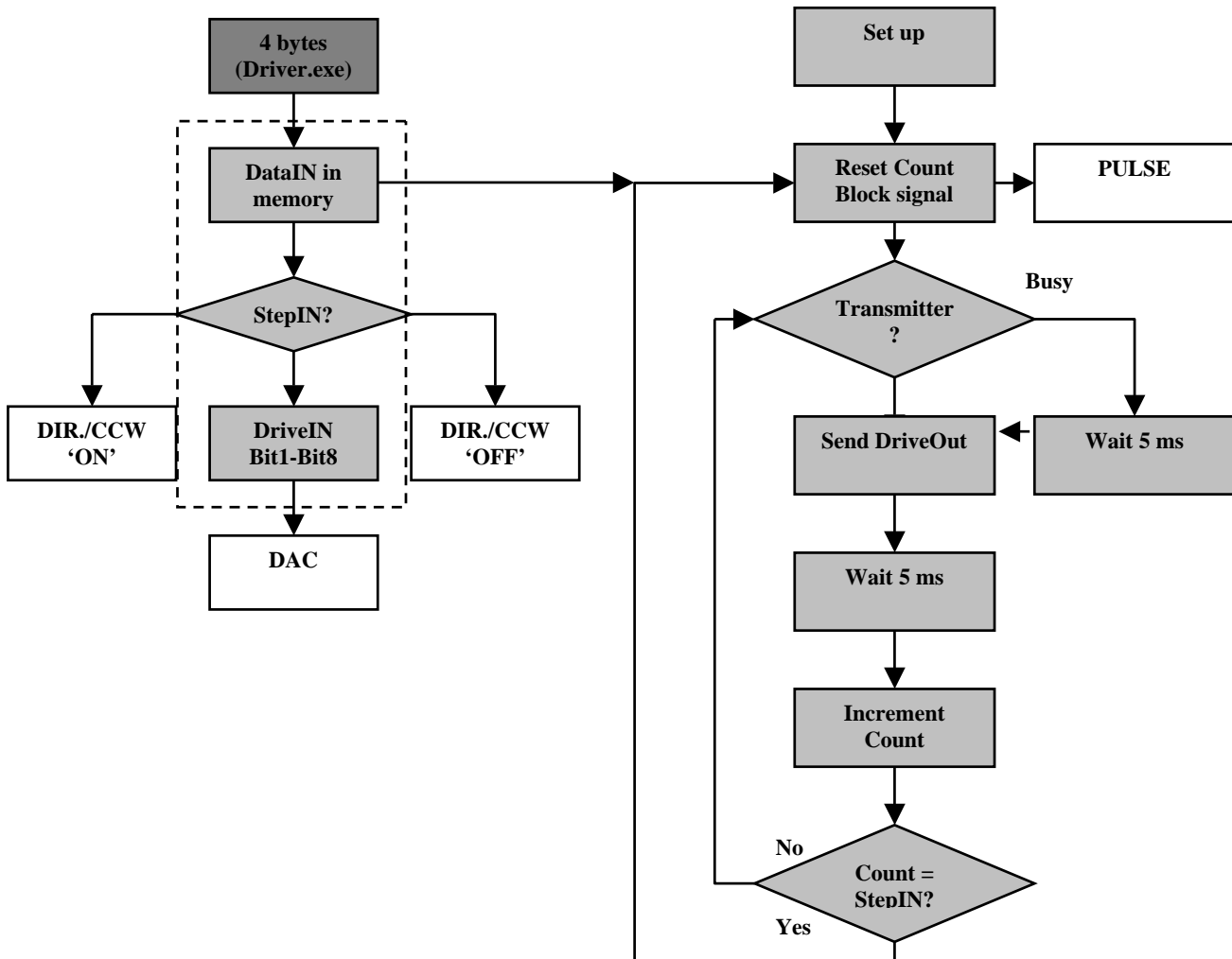

Fig.4.32
Flow chart

First of all the PIC controller is initialised in the set up module. This means all input and output directions are chosen, and the interrupt is initialised. After this we enter the main loop of the program.

The main loop is a counter. Each count takes $2.5ms$. The number we are counting to is actually the value of StepIN2 without bit8, and is called StepIN3. When the counter has reached this value, the counter resets, and a data signal is put on portA, bit2. The signal (connected with PULSE) changes from ‘high’ to ‘low’ remains low for $2.5ms$ and changes back from ‘low’ to ‘high’. This way we have made a block signal with a variable frequency. The frequency is determined by the horizontal slider on the control panel and lays between $3.125Hz$ and $133.3Hz$. The frequency is not linear but the period is! In the main loop we send also a byte back to the computer, before doing this we check if the transmitter is busy or not. When it is busy, we wait $5ms$ and try again to send the byte.

All different modules are now worked out, and can be implemented on the mechanical platform. In the next chapter we take a closer look at the kinematics of the developed mechanical platform.

5 Kinematics

5.1 Introduction

Kinematics is the study of the mathematics of motion without considering the forces that affect the motion. Robot kinematics describes robot movements. We need to understand the mechanical behaviour of the robot both in order to design the mobile robot for desired tasks and to create control software for the mobile robot hardware. The main question to be answered in this context is: ‘Given a certain steering angle and a number of wheel turns, where will the robot end up and which way will it be pointed?’ This problem is relatively simple. It deals with the geometric relationships that influence the system, and with the relationship between control parameters and the behaviour of a system in state space.

In robotics, the inverse problem is usually more interesting. Given that we want to arrive to a certain position, oriented in a certain direction, the problem of inverse kinematics is to compute the set of robot operations which will achieve the goal. The solution to a inverse kinematic problem is almost always overdetermined.

Locomotion is the process of causing a mobile robot to move. In order to produce motion, forces must be applied tot the vehicle. Dynamics is the study of motion in which these forces are modelled. It deals with mass, force and speed associated with these motions. The mobile robot is limited by dynamics. For instance, a high centre of gravity limits the turning radius of a fast robot because of the danger of rolling.

5.2 Kinematics

Deriving a model [10] for the whole robot's motion is a bottom-up process. Each wheel imposes constraints on the robot's motion. The kinematics of an individual wheel and later the kinematics of the whole robot will be annotated but first a global reference frame and the local reference frame is defined to represent the robot's position.

5.2.1 Representing Robot's Position

In Fig.5.1 we model the robot as a rigid body on wheels, operating on a horizontal

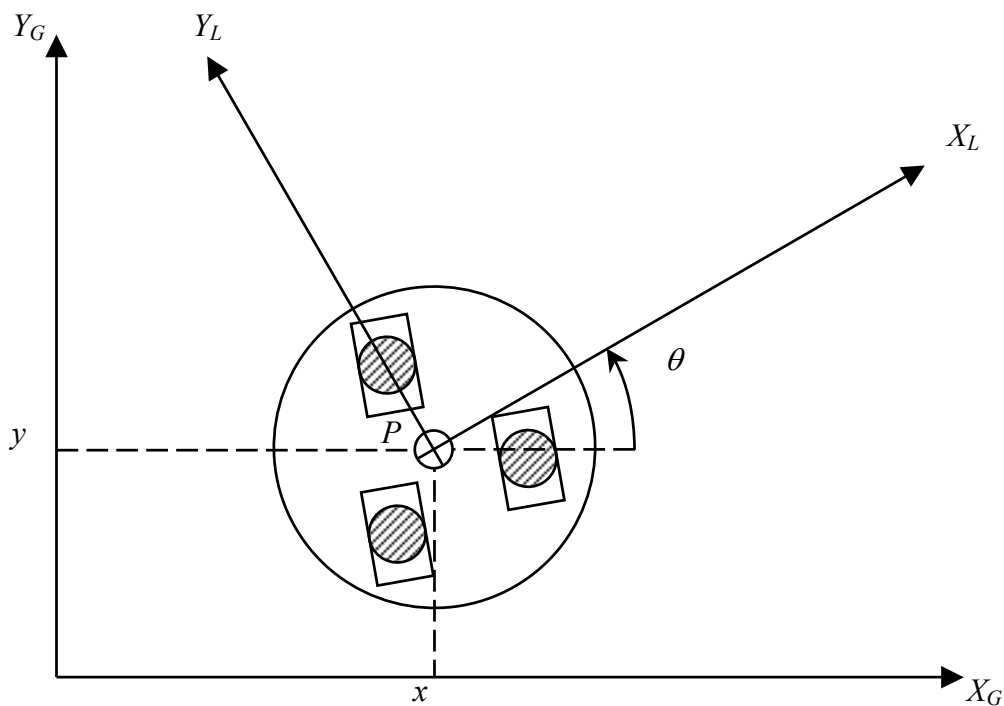

Fig.5.1
Robot model as rigid body in global and local reference frame

plane. The global reference frame is given by the axes X_G and Y_G as they define an arbitrary inertial basis on the plane from some origin O . To specify the position of the robot, we choose a point P on the robot chassis as its position reference point. The basis defined by the axes X_L and Y_L relative to P on the robot chassis is the robot's local reference frame. The position P in the global reference frame is given by coordinates x and y . The angular difference between the two frames is given by θ . We put these three elements in a vector Φ_G :

$$\Phi_G = \begin{bmatrix} x \\ y \\ \theta \end{bmatrix} \quad (5.1)$$

This vector describes the robot's posture in the global reference frame.

To describe the motion of the robot, it is necessary to map motion along the axes of the global reference frame to motion along the axes of the robot's local reference frame. This mapping is function of the current pose of the robot, and is accomplished using the orthogonal rotation matrix R :

$$R = \begin{bmatrix} \cos \theta & \sin \theta & 0 \\ -\sin \theta & \cos \theta & 0 \\ 0 & 0 & 1 \end{bmatrix} \quad (5.2)$$

The rotation matrix expresses the orientation of the base frame with respect to the moving frame.

Given some velocity in the global reference frame $\{X_G, Y_G\}$ we can compute the components of motion along the robot's local axes X_L and Y_L by:

$$\dot{\Phi}_L = R(\theta)\dot{\Phi}_G \quad (5.3)$$

A forward kinematic model would predict the robot's overall speed in the global reference frame. From equation (5.4) we can compute the global motion from the local motion:

$$\dot{\Phi}_G = R(\theta)^{-1}\dot{\Phi}_L \quad (5.4)$$

5.2.2 Kinematic Wheel Model

The first step to a kinematic model is to express constraints on the motions of individual wheels. Later these results are combined to compute the whole robot's motion. The synchro drive configuration has three steered standard wheels. Lets focus on the kinematics of a steered standard wheel. A few assumptions are made to simplify the equations. We assume:

- A movement on a horizontal plane.
- The steering axes orthogonal to the surface.
- The plane of the wheel remaining vertical.
- Point contact of the wheels.
- Pure rolling.
- No slippage.
- No friction for rotation around the contact point.
- That the wheels are not deformable.
- The wheels connected to the chassis.

Under these assumptions the wheel has two constraints. The first constraint enforces the concept of rolling contact. This means that the wheel must roll when motion take place in the appropriate direction. The second constraint enforces the concept of no lateral slippage. This means that the wheel must not slide orthogonal to the wheel plane.

A steered standard wheel connected to the chassis and its parameters is shown in Fig.5.2. The position of the wheel in the local reference frame is given in polar coordinates by the distance l and the angle α . The wheel can spin over time, and is steerable, so β and φ are function of time t . Note that a fixed standard wheel has a fixed steering angle β which is not function of time t .

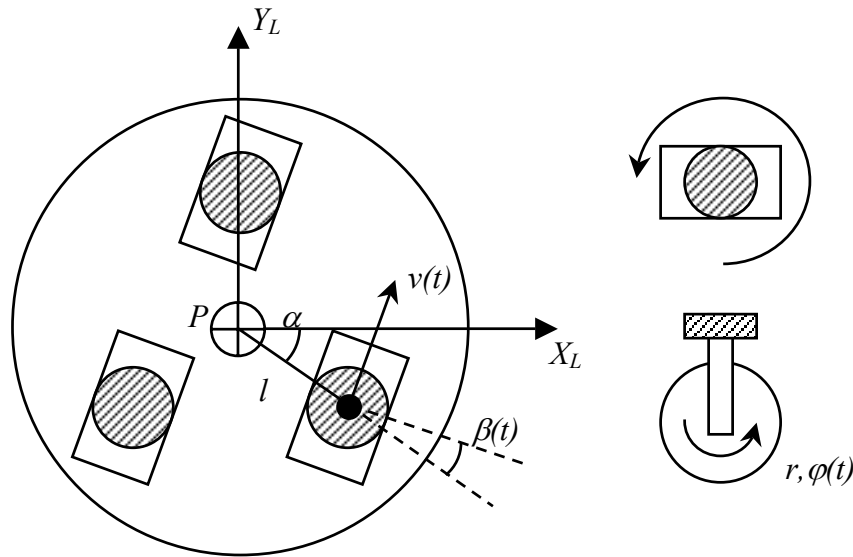

Fig.5.2
Synchro drive with three steered standard wheels in local reference frame and its parameters

The rolling constraint for the wheel is given by equation (5.5):

$$[\sin(\alpha + \beta) \quad -\cos(\alpha + \beta) \quad -l \cos \beta]R(\theta)\dot{\Phi}_G - r\dot{\varphi} = 0 \quad (5.5)$$

The first term denotes the total motion along the wheel plane, and must be equal to the motion accomplished by the spinning wheel, $r\dot{\varphi}$.

The sliding constraint for the wheel is given by equation (5.6):

$$[\cos(\alpha + \beta) \quad \sin(\alpha + \beta) \quad l \sin \beta]R(\theta)\dot{\Phi}_G = 0 \quad (5.6)$$

The component of the wheel's motion orthogonal to the wheel plane must be zero.

5.2.3 Kinematic Robot Model

Now that we have a model for one steered standard wheel we can compute the kinematic constraints of the whole robot chassis. Our chassis has three steered standard wheels. However, the procedure to compute the kinematic robot model is used for other wheel configurations as well. In general, given a robot with N standard

wheels, comprising N_f fixed and N_s steerable. Each standard wheel imposes constraints on the robot motion. We can develop the equations for constraints in matrix forms. The rolling constraints of all wheels can now be collected in a single expression:

$$C_{R1}R(\theta)\dot{\Phi}_G - C_{R2}\dot{\phi} = 0 \quad (5.7)$$

with

$$C_{R1} = \begin{bmatrix} C_{R1f} \\ C_{R1s}(\beta_s(t)) \end{bmatrix} = C_{R1}(\beta_s(t)) \quad (\text{Nx3}) \quad (5.8)$$

$$C_{R2} = \begin{bmatrix} r_{1f} & 0 & \dots & \dots & \dots & 0 \\ 0 & \dots & 0 & \dots & \dots & \dots \\ \dots & 0 & r_{Nf} & 0 & \dots & \dots \\ \dots & \dots & 0 & r_{1s} & 0 & \dots \\ \dots & \dots & \dots & 0 & \dots & 0 \\ 0 & \dots & \dots & \dots & 0 & r_{Ns} \end{bmatrix} \quad (\text{NxN}) \quad (5.9)$$

$$\dot{\phi} = \begin{bmatrix} \dot{\phi}_f(t) \\ \dot{\phi}_s(t) \end{bmatrix} = \dot{\phi}(t) \quad (\text{Nx1}) \quad (5.10)$$

We use the same technique to collect the sliding constraints of all standard wheels into a single expression with the same structure:

$$C_S R(\theta)\dot{\Phi}_G = 0 \quad (5.11)$$

$$C_S = \begin{bmatrix} C_{Sf} \\ C_{Ss}(\beta(t)) \end{bmatrix} = C_S(\beta(t)) \quad (\text{Nx3}) \quad (5.12)$$

Next we can use the sliding constraints in conjunction with the rolling constraints to generate analyses of the manoeuvrability of a robot chassis. The manoeuvrability is a combination of the mobility available based on the sliding constraints plus additional

freedom contributed by the steering. First we define the degree of mobility, and the degree of steerability, then the degree of manoeuvrability will follow.

5.2.3.1 Degree of Mobility

To satisfy equation (5.11), the motion vector $R(\theta)\dot{\Phi}_G$ must belong to the null space of the projection matrix $C_S(\beta(t))$. This is the space N such that for any vector n in N equation (5.13) is true:

$$C_S(\beta(t)) \cdot n = 0 \quad (5.13)$$

If the kinematic constraints are to be honoured, then the motion of the robot must always be within this space N . This can be demonstrated geometrically using the concept of a robot's 'instantaneous centre of rotation.'

Consider a single standard wheel as in Fig.5.3.a. It is forced by equation (5.6) to have zero lateral motion. We can show this geometrically by drawing a zero motion line through its horizontal axis. At any given instant, wheel motion along the zero motion line must be zero. More specific, the wheel must be moving instantaneously along some circle of radius R such that the centre of that circle is located on the zero motion line. This point is called the instantaneous centre of rotation, ICR. When R is at infinity, the wheel moves in a straight line.

A vehicle can have several wheels, but it can have only one ICR. All of its zero motion lines have to meet at a single point. Placing the ICR in this point gives the single solution for robot motion. This is why the front wheels of a car have a different steer angle as pictured in Fig.5.2.d. So with the geometric construction we can see that the robot's mobility is a function of the number of constraints of motion, instead of the number of wheels.

For instance, in Fig.5.3.b and Fig.5.3.c two two-wheeled configurations are shown. The first configuration, the bike type, has two lines of zero motion, because of each wheel contributes a constraint. The two constraints are independent, and thus each

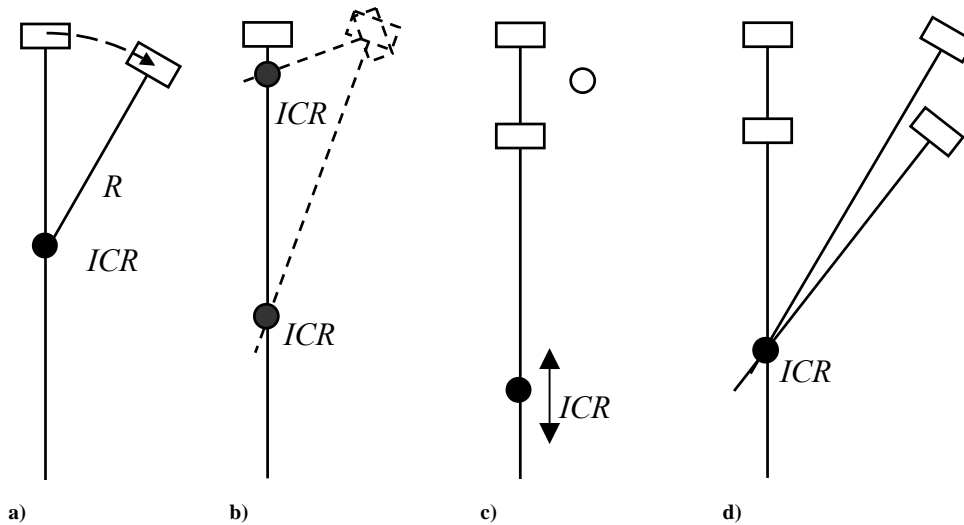

Fig.5.3
Instantaneous Centre of Rotation for: a) Single standard wheel, b) Bike type, c) Differential drive, d) Car drive

further constraints overall robot motion. The second configuration is the differential drive mechanism. The two wheels are aligned along the same horizontal axis. The ICR lies along a line, not at a specific point. The second wheel imposes no additional kinematic constraint on the robot motion since its zero motion line is identical to that of the first wheel. Although both configurations have the same number of standard wheels, the former has two independent kinematic constraints while the latter has only one.

So, the robot chassis kinematics is therefore a function of the set of independent constraints arising from all standard wheels. The mathematical interpretation of independence is related to the rank of the matrix $C_s(\beta(t))$ (5.12). The greater the rank, the more constrained is the mobility. We can identify the possible range of rank values for any robot. In general the robot has zero or more standard wheels, and zero or more omnidirectional wheels. However, the omnidirectional wheels do not contribute to the constraints of motion. A robot with only omnidirectional wheels has rank zero. The maximum possible rank is three since the kinematic constraints are specified along three degrees of freedom, or we can see that the constraint matrix has three columns. So the possible rang of rank values is:

$$0 \leq \text{rank}[C_S(\beta(t))] \leq 3 \quad (5.14)$$

Now we are ready to define a robot's degree of mobility δ_m :

$$\delta_m = 3 - \text{rank}[C_S(\beta(t))] \quad (5.15)$$

Consider a robot with only omnidirectional wheels. The rank is zero, and the degree of mobility is three. In other words, there are no constraints on the chassis, such a robot can directly manipulate all three degrees of freedom. The other extreme, a robot with three independent constraints generated by three standard wheels, has rank three, and its degree of mobility is zero. More specific, the robot is completely constrained in all directions, and motion in the plane is totally impossible.

5.2.3.2 Degree of Steerability

The degree of mobility quantifies the degree of controllable freedom based on changes to wheel velocity. Steering can also have an impact on a robot chassis. This impact is indirect because after changing the angle of a steerable standard wheel, the robot must move to have an impact on the robot's pose. We can define the degree of steerability δ_s as:

$$\delta_s = \text{rank}[C_{S_s}(\beta(t))] \quad (5.16)$$

Note that we care about the number of independently controllable steering parameters. In equation (5.12) we can see that $C_S(\beta(t))$ includes $C_{S_s}(\beta(t))$, this means that a steered standard wheel can both decrease mobility and increase steerability at once. The particular orientation of the steered standard wheel at any instant imposes a kinematic constraint, but its ability to change that orientation can lead to additional trajectories.

The range of the degree of steerability is:

$$0 \leq \delta_s \leq 2 \quad (5.17)$$

When δ_s is zero, the robot has no steerable standard wheels. When δ_s is two, the robot has no fixed standard wheels. For instance a pseudo bicycle in which both wheels are steerable. It is possible to place the ICR anywhere on the ground plane when δ_s is two. Most robots have a single degree of steerability.

5.2.3.3 *Degree of Manoeuvrability*

With the degree of mobility δ_m and the degree of steerability δ_s we have all the tools to compute the overall degree of freedom that a robot can manipulate. The degree of manoeuvrability is defined as:

$$\delta_M = \delta_m + \delta_s \quad (5.18)$$

The degree of manoeuvrability includes both the degree of freedom that the robot manipulates directly through wheel velocity, and the degree of freedom that it indirectly manipulates by changing the steering angle and moving.

5.2.4 Synchro Drive

Now we use the developed tools on our robot chassis. The robot has zero fixed wheels, and three steered wheels. The three wheels do not share a common axle, therefore two of the three contribute independent sliding constraints. The third must be dependent on these two constraints for motion to be possible. The degree of mobility is one. This is intuitively correct, the chassis with frozen steering angle of the wheels can only move back and forth on a straight line. Based on equation (5.16) the robot should have a degree of steerability of two. However in a synchro drive principle a single motor steers all three wheels together. Therefore the system has an extra constraint such that in reality the degree of steerability equals one. The manoeuvrability based on these values equals two. This result implies that the

synchro drive can only manipulate two degrees of freedom. In fact there is no way to change the chassis' orientation, only the position on the plane can be manipulated. In our case we add to possibility to change the orientation of the upper platform when the robot is at rest because the upper platform is connected with the steering motor. That way we have developed a non holonomic but omnidirectional robot chassis.

6 Conclusions and Further Work

6.1 Conclusions

In this thesis ‘Autonomous Mobile Robot: Mechanical Design’ a sub part of the project ‘Autonomous Mobile Robot’, a locomotion mechanism is designed and developed. This locomotion mechanism will form the chassis of an autonomous mobile robot. The robot will be used in well structured engineered environments, on flat surfaces, such as office buildings. In these circumstances a three wheeled, cylindrical chassis will perform well. The three wheels ensure ground contact, without the need of a complex suspension mechanisms. The shape, in combination with omnidirectionality, avoids getting trapped easily. A symmetrical, cylindrical, three wheeled configuration is worked out.

The designed chassis has a non holonomic behaviour. In fact the chassis’ orientation can not be changed in direction. However, to create an omnidirectional system the robot is divided into two parts. A mechanical, lower platform that is worked out in this thesis, and an upper platform. The upper platform has to be mounted on a specific part in the mechanical platform. This specific part is mechanically coupled with the steer motor. That way we can orient the upper platform in any desired direction when the robot is at rest, making the entire system omnidirectional.

Three driven steered standard wheels are used to produce motion. A chain transmission is used to transmit the rotary power of the single drive motor to all three the wheels. Another chain transmission transmits the rotary power of the single steer motor to all three the wheels and the upper platform. That way the orientation of the three wheels and the upper platform can be changed. Mechanisms to align easily the three wheels and upper platform are implemented in the design.

The mechanical platform is also equipped with a microcontroller and specific motor electronics. Interface electronics allows us to control the motors with the

microcontroller. That way the mechanical platform, with its own energy supply, more specific a battery pack, can be used individually for different applications.

To test the low level components, a high level operating and control system is developed and can be used as a driver to control the motion of the mechanical platform. After testing each module on its own, all modules were combined and the motors were tested without load in a testing frame. These experiments were successful.

Further Work

My fellow-students and I have worked out most of the major parts needed for the desired autonomous mobile robot. However some more tests, the combining of the different components and the last parts still have to be worked out before the robot can actually be built to perform all its desired tasks.

Applied to the locomotion mechanism described in this work, some dynamic experiments should be done to tune the mechanical platform even further and to describe its dynamics. Unfortunately the time for this project was limited and these data could not yet be obtained.

Also the upper platform still has to be worked out in more detail. As said before that platform must contain the computer with the high level software and the sensor casing needs to be fixed and aligned with the wheels to get a view of the environment.

It is clear that there is still work to do and that all the efforts made in the different fields will have to be combined to achieve the main aim: building an autonomous mobile robot. Hence it becomes clear once again that robotics really is a challenging and interdisciplinary field.

Abbreviations

| | |
|-----|-------------------------------|
| PC | Personal Computer |
| CAD | Computer Aided Design |
| DC | Direct Current |
| CCW | Counter Clock Wise |
| CW | Clock Wise |
| PCB | Printed Circuit Board |
| DAC | Digital to Analogue Converter |
| ADC | Analogue to Digital Converter |

List of Figures

| | | |
|----------|---|----|
| Fig.2.1 | A sequential Design Process [7] | 4 |
| Fig.3.1 | A biped walking system[10] | 9 |
| Fig.3.2 | Specific power versus attainable speed of various locomotion mechanisms[10] | 9 |
| Fig.3.3 | Standard Wheels | 12 |
| Fig.3.4 | Omnidirectional Wheels | 13 |
| Fig.3.5 | Legend | 14 |
| Fig.3.6 | Static unstable two-wheeled configuration | 15 |
| Fig.3.7 | Bike | 15 |
| Fig.3.8 | Static stable two-wheeled configuration, if the centre of mass is below the wheel axle. | 16 |
| Fig.3.9 | Cye, a commercial two-wheel differential-drive robot | 16 |
| Fig.3.10 | Differential drive configuration with two drive wheels and a castor wheel. | 17 |
| Fig.3.11 | Khepera, a small differential drive robot. | 17 |
| Fig.3.12 | Tri-cycle drive, front/rear steering and rear/front driving. | 18 |
| Fig.3.13 | Piaggio mini truck | 18 |
| Fig.3.14 | Tri-cycle drive, combined steering and driving | 19 |
| Fig.3.15 | Neptune | 19 |
| Fig.3.16 | Synchro drive wheel configuration | 20 |
| Fig.3.17 | MRV4 robot with synchro drive mechanism | 20 |
| Fig.3.18 | Front driven/steered Ackerman steering | 22 |
| Fig.3.19 | Front steered/rear driven Ackerman steering | 22 |
| Fig.3.21 | Articulated drive configuration | 23 |
| Fig.3.22 | Construction worker with articulated drive | 23 |
| Fig.3.23 | Slip/skid wheel configuration | 24 |
| Fig.3.24 | Nanokhod, an autonomous robot with tracks | 24 |
| Fig.3.25 | Omnidirectional configuration with three spherical wheels | 25 |
| Fig.3.26 | Robot with three omnidirectional wheels | 25 |
| Fig.3.27 | Omnidirectional configuration with four spherical wheels | 26 |
| Fig.3.28 | Uranus, a four omnidirectional wheeled robot | 26 |
| Fig.4.1 | Black box analogy and final mechanical platform | 28 |
| Fig.4.2 | Cylindrical versus square robot shape | 29 |
| Fig.4.3 | Black box analogy considering general dimensions and shape | 30 |
| Fig.4.4 | Black box analogy, upper and lower platform | 32 |
| Fig.4.5 | Synchro drive with attached sensor casing | 33 |
| Fig.4.6 | a) NIMH SPECIALE ACCU 13000F-1Z b) Battery pack with twenty cells | 35 |
| Fig.4.7 | Charge Terminal 3000 [17] | 38 |
| Fig.4.8 | Black box analogy, symmetrical concept of the lower platform | 39 |
| Fig.4.9 | Robot's leg | 40 |
| Fig.4.10 | a) Right-angle driver b) Modified right-angle driver | 41 |

List of Figures

| | | |
|----------|---|----|
| Fig.4.11 | a) Overview leg b) Detail view of the fork with transmission and mechanism to tighten the small chain c) Section view of the wheel spindle and detail view of the bearing housing | 42 |
| Fig.4.12 | a) Overview leg b) Detail view of the assembly of the steer and drive mechanism | 43 |
| Fig.4.13 | a) Partial assembled leg b) Bearing housing leg c) Complete assembled leg | 44 |
| Fig.4.14 | Simple vehicle model | 46 |
| Fig.4.15 | Maxon motor (RE36) with gearhead GP32A(18:1) and encoder (HEDL5540)[20] | 48 |
| Fig.4.16 | Characteristics stepper motor [21] | 50 |
| Fig.4.17 | Vexta stepper motor (CSK268MBT)[21] | 52 |
| Fig.4.18 | Blackbox analogy | 53 |
| Fig.4.19 | Main socle and its inner parts | 54 |
| Fig.4.20 | Supporting frame | 54 |
| Fig.4.21 | a) Transmission mechanism b) Upper chain c) Lower chain | 55 |
| Fig.4.22 | a) Mechanical platform and implementation transmission mechanism b) Real mechanical platform | 56 |
| Fig.4.23 | Control loops | 58 |
| Fig.4.24 | Three electronic modules used in the mechanical platform | 59 |
| Fig.4.25 | a) Servo amplifier (ADS 50/5) b) Inputs and outputs | 60 |
| Fig.4.26 | a) Stepper amplifier (CSK 2-Phase)[22] b) Inputs and outputs | 62 |
| Fig.4.27 | One-pulse stepper motor operation[22] | 63 |
| Fig.4.28 | Interface electronics | 64 |
| Fig.4.29 | Relationship high and low level software | 67 |
| Fig.4.30 | Control panel: Driver.exe | 68 |
| Fig.4.31 | Values horizontal slider used in Driver.exe | 69 |
| Fig.4.32 | Flow chart | 70 |
| Fig.5.1 | Robot model as rigid body in global and local reference frame | 73 |
| Fig.5.2 | Synchro drive with three steered standard wheels in local reference frame and its parameters | 76 |
| Fig.5.3 | Instantaneous Centre of Rotation for: a) Single standard wheel, b) Bike type, c) Differential drive, d) Car drive | 79 |

References

- [1] J. Defever B. Francis and T. Geerinck, “Mobile Robots with Shared Autonomy”, Vrije Universiteit Brussel, Brussels, Belgium, 2004
- [2] J. Defever “Mobile Robots with Shared Autonomy: Navigation Control”, Vrije Universiteit Brussel, Brussels, Belgium, 2004
- [3] B. Francis, “Mobile Robots with Shared Autonomy: Visual Servoing”, Vrije Universiteit Brussel, Brussels, Belgium, 2004
- [4] T. Geerinck, “Mobile Robots with Shared Autonomy: Tele-Robotics”, Vrije Universiteit Brussel, Brussels, Belgium, 2004
- [5] NN, “Competition rules Melexis Safety Trophy”, <http://www.trophy.melexis.com/>, Belgium, 2005
- [6] I.J. Cox G.T. Wilfong, “Autonomous Mobile Vehicles”, NEC Research Institute QT&T Bell Laboratories, Princeton, Murray Hill, USA, 1990
- [7] Victor H. Mucino, “Computer Aided Design Through Engineering Case Studies”, College of Engineering and Mineral Resources, West Virginia University, West Virginia, 1997
- [8] P. Kool, “Robotica”, Vrije Universiteit Brussel, Brussels, Belgium, 2000
- [9] Robert Holmberg, “Design and Development of Powered-Castor Holonomic Mobile Robots”, Stanford University, 2000
- [10] Roland Siegwart, Illah R. Nourbakhsh “Introduction to Autonomous Mobile Robots”, The MIT Press, Massachusetts Institute of Technology, Cambridge, Massachusetts, 2004
- [11] Mike Ashby, Kara Johnson “Materials and Design”, Butterworth-Heinemann, Oxford, 2002
- [12] Mike Ashby, “Materials Selection in Design”, Butterworth-Heinemann, Oxford, 1999
- [13] Datasheet, “ultra sonic sensor 6500 Polaroid”, www.robotstorehk.com/6500.pfd
- [14] Datasheet, “digital compass Devantech”, www.robot-electronics.co.uk/
- [15] Datasheet, “Infrared sensor Sharp GP2D12”, www.zuff.info/SharpGP2D12_E.html
- [16] Datasheet, “pan/tilt camera Sony EVI-D31”, www.picturephone.com/pdf/sony_evid30.pdf
- [17] Datasheet, “Charge Terminal 3000”, www.conrad.com
- [18] NN, “SKF angular contact ball bearings-your key to longer service life”, SKF, www.skf.com, 2002
- [19] NN, “SKF General Catalogue”, SKF, Germany, 2005
- [20] Datasheet, “Maxon motor RE36”, www.maxonmotor.com
- [21] Datasheet, “Vexta Stepper CSK 2-phase”, www.orientalmotors.com
- [22] Datasheet, “Maxon servo amplifier ADS 50/5”, www.maxonmotor.com
- [23] Datasheet, “PIC16F87XA Data Sheet”, www.microchip.com
- [24] Datasheet, “Traco Power DC/DC-Konverter TEN4Serie”, www.tracopower.com
- [25] Datasheet, “MAX232”, www.maxim-ic.com
- [26] Datasheet, “8-bit high-speed multiplying D/A Converter”, www.philipssemiconductors.com
- [27] Datasheet, “Microcontroller Compatible 8-bit A/D Converter”, www.maxim-ic.com